

SEEBURG

WALL-O-MATIC "200"

TYPE V3WAN and V3WAD

Seeburg

WALL-O-MATIC "200"
TYPES "V-3WA-N" and "V-3WA-D"

The Wall-O-Matic "200", Type V-3WA-N and Type V-3WA-D, are a part of the Seeburg Wired Remote Control System for selective playing of any of the selections in the Select-O-Matic "200" phonograph. They operate in conjunction with the Selection Receiver in the phonograph to which they are connected with a 3-conductor cable. The two types are the same in all respects except the selection pricing specifications. In both types the coins are deposited in a single entry coin chute and pass through a 5-, 10-, 25-cent slug rejector and the coin switches into the cash box. Each nickel, dime and quarter adds, respectively, one, two and six credits in an add-and-subtract credit unit that has a capacity of twenty-four credits and is part of the Seeburg Dual Selection System. A selection pricing panel permits pricing of tunes so that either of two predetermined values of credits is cancelled when a record is selected.

The Type V-3WA-D is equipped with a Dual Credit Unit, Type DCU10, that permits tunes to be priced at 10 cents (3 for a quarter) and 15 cents (2 for a quarter). When this Credit Unit is used, two credits (10 cents) or three credits (15 cents) are subtracted from the credits totaled in the Dual Credit Unit when a selection is made. The Type V-3WA-N is equipped with a Dual Credit Unit, Type DCU15, that permits pricing of selections at 5 cents (6 for a quarter) and 10 cents (3 for a quarter). When this Credit Unit is used, one credit (5 cents) or two credits (10 cents) are subtracted from the total credit when a selection is made.

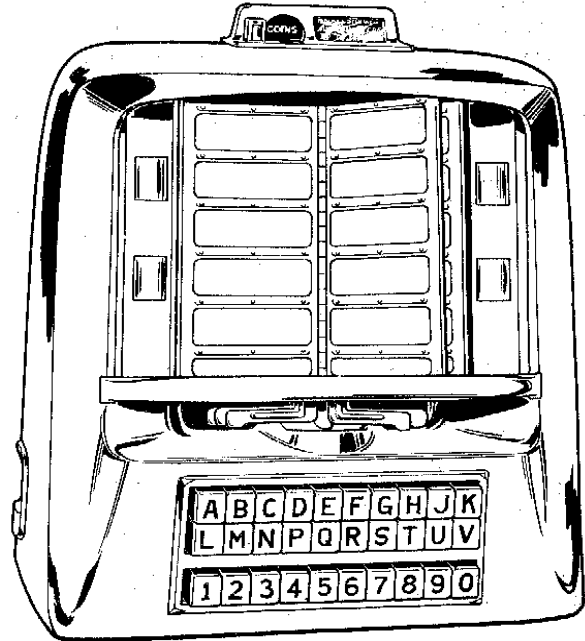

Information panels at each side of the program holder are illuminated to indicate when additional coins are needed for selections or when there is enough accumulated credit for any selection.

INSTALLATION INSTRUCTIONS

To mount the Wall-O-Matic, first unlock it and remove the cover. There are three holes in the back plate for mounting. The upper two are slotted for fitting over screws already set in the wall at the proper points. The lower hole is for rigid mounting, by means of a screw, after the Wall-O-Matic has been hung in place.

If the mounting place on the wall is uneven, the Wall-O-Matic mounting plate should be shimmed with cardboard or wood before tightening the three mounting screws. Tightening these screws on an uneven wall will bend the mounting plate, may seriously effect the operation of the Wall-O-Matic and will cause the cover and lock to bind. The upper right hand and lower screws are accessible for tightening directly through clearances provided. To secure the upper left

hand mounting screw it is necessary to remove the slug rejector as follows:

- A. Unlatch the program holder, lift up and out on the assembly.
- B. Remove the credit light assemblies.
- C. Unscrew 1, 2 and 3 (Figure 2).
- D. Lift the reject button and lift out the slug rejector.

After the Wall-O-Matics are mounted in their respective locations, the cabling can be installed. Use inter-connecting cable, *Seeburg Part No. 12001*, which can be purchased in lengths to suit requirements. At the Select-O-Matic, a cable plug, *Seeburg Part No. 12015*, is

WALL-O-MATIC, TYPES "V-3WA-N" and "V-3WA-D"

soldered to the end of the cable. Solder the blue wire to No. 1, the orange wire to No. 2, and the green wire to No. 3 of the plug. The plug fits into a 3-conductor socket in the Tormat Selection Receiver.

The plug and cable may be connected to from one to six wired Wall-O-Matics. The 3-conductor socket in the Tormat Selection Receiver will supply power for up to 6 Wall-O-Matics. If more than 6 are connected to the circuit, the trans-

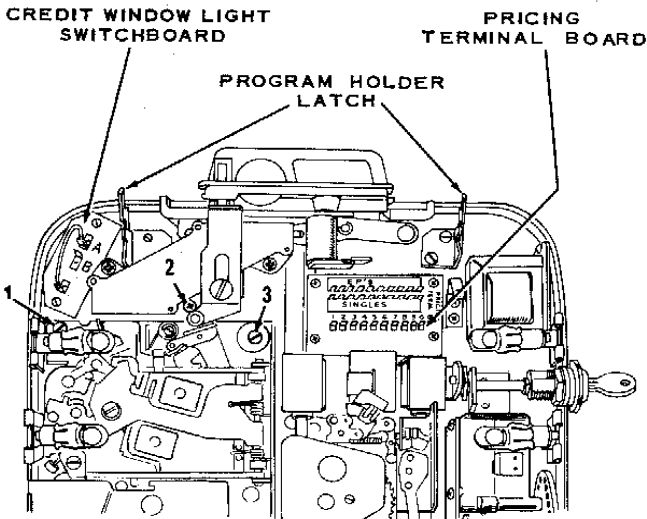

Figure 2.

former supplying power to the circuit may be burned out. If the installation requires more than 6 Wall-O-Matics an auxiliary power supply, Type PS6-1Z, must be used for each additional circuit.

The terminal strip in the Wall-O-Matic is color coded in the same colors as the cable. Solder one lug to each of the cable wires (six soldering lugs are furnished with each Wall-O-Matic). Connect the blue wire of the cable to the blue of the terminal strip, the orange wire to the orange of the terminal strip (ground) and the green wire to the green of the terminal strip. When the Wall-O-Matic is used as the junction of two cables, two conductors will be on each terminal.

The Wall-O-Matics are supplied with terminal brackets for open wiring installations. If concealed wiring is desired, a knock-out hole in the lower left hand corner of the mounting plate is provided for entry of the cables.

Bar Bracket Assembly, Seeburg Part No. 500200, is available for rigidly mounting the Wall-O-Matic on bars, counters and tables.

The Wall-O-Matic has been thoroughly tested before leaving the factory. Unless damaged in shipment, no adjustments should be necessary.

"SET-UP" AND OPERATION OF DUAL CREDIT SYSTEM FOR TYPE V-3WA-D

The Dual Credit System as applied to the Wall-O-Matic "200", Type V-3WA-D uses Dual Credit Unit Type DCU10. It is designed to provide "Single" selections for 10¢ and "EP's" for 15¢.

The "200" Wall-O-Matic incorporates a Dual Credit System which permits the accumulation of credits at the rate of one credit for a nickel, two credits for 2 nickels or a dime, and three credits for 15 cents. Additional credits can be accumulated up to a maximum of 24 in each programming cycle. Note that a premium is given when quarters are used, since one quarter gives six credits and four quarters will give 24, while it takes 12 dimes or 24 nickels to give 24 credits.

Figure 3 constitutes a chart condensing information regarding the capabilities and set-up requirements for the three pricing combinations.

Preparation of the system necessitates:

- A. Setting up of the Credit Window Light Switchboard for correct indication of credits.

PRICING COMBINATIONS

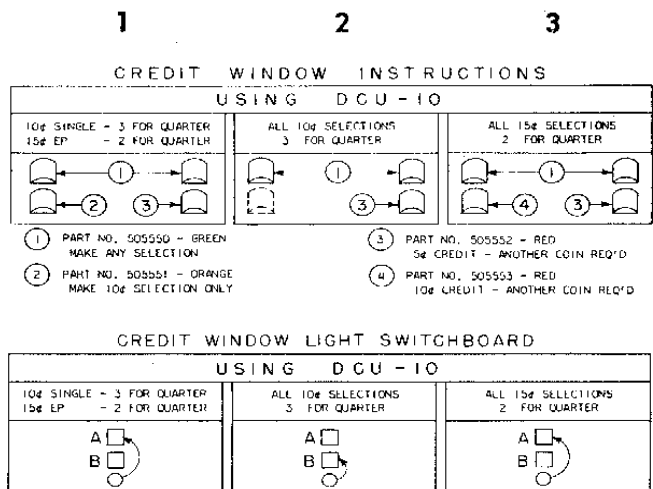

Figure 3.

- B. Connecting the Pricing Terminal Board taper tabs corresponding to each panel of desired "EP's" and "SINGLES"

WALL-O-MATIC, TYPES "V-3WA-N" and "V-3WA-D"

for associated pricing. The program must be in panels of 20 selections (10) records, each panel being represented by a number button. "Singles" and "EP's" cannot be in the same panel if there is to be a price difference. *The pricing terminal board on the Tormat Selection Receiver, the pricing terminal board on the Tormat Electrical Selector, and the pricing terminal boards in all Wall-O-Matics MUST be connected to match.*

With the Credit Window Light Switchboard set to "A", as in pricing combination No. 1, and the Pricing Terminal Board connected for "SINGLES" & "EP's", the following operational sequence holds true:

1. The deposit of a nickel rotates the credit wheel in the Dual Credit Unit to the one-credit position and the lower right credit window light goes on indicating "5¢ Credit - Another Coin Required". No plays will result when selection buttons are pushed.
2. Another nickel (or a dime initially) rotates the credit wheel to the two-credit position and the lower left credit window light goes on indicating "Make 10¢ Selection Only". Now only "Singles" plays will result when proper selection buttons are pushed. If buttons for "EP" selection are depressed no selection will result unless another nickel is deposited.
3. Another nickel (or a nickel and a dime initially) rotates the credit wheel to the three-credit position and the upper two credit window lights go on indicating "Make Any Selection". Credit window lights remain the same as when on the three-credit position, with the deposit of additional coins.

With the Credit Window Light Switchboard set on position "B" and the Pricing Terminal Board tabs all placed on "Singles" as in pricing combination No. 2, the following holds true:

1. The first nickel deposited rotates the credit wheel to the one-credit position and the lower right credit window light goes on as before.
2. Another nickel (or a dime initially) rotates the credit wheel to the two-credit position and the upper credit window lights go on indicating "Make

Any Selection". The lower left credit light remains out at all times with the switchboard in "B" position.

With the Credit Window Light Switchboard set on position "A" and the Pricing Terminal Board tabs all placed on "EP's" as indicated in pricing combination No. 3, the following holds true:

1. The Dual Credit Unit operation is similar to that of the previous "A" switchboard set-up, however, no plays will result on the first two credit positions.
2. In the 2-credit position, the lower left credit window lights up to indicate "10¢ Credit - Another Coin Required". This credit window, Part No. 505553 is available from your Seeburg Distributor and is installed as shown in Figure 4.

Appropriate Classification Headings required to satisfy a desired pricing combination may be chosen from the tabulated listing, Figure 5.

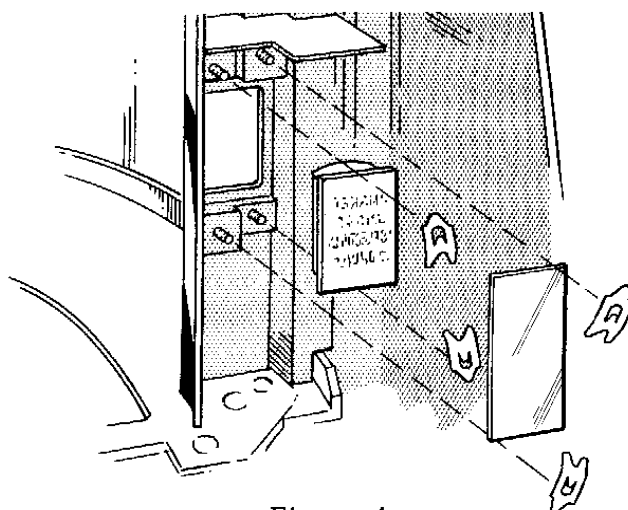

Figure 4.

CLASSIFICATION HEADING	PART NUMBER	
	10¢ SINGLES	15¢ EP's
HIT TUNES	505779	505840
RHYTHM & BLUES	505780	505841
FOLK & WESTERN	505781	505842
ALL TIME FAVORITES	505782	505843
CLASSICS & VARIETIES	505783	505844

Figure 5.

"SET-UP" AND OPERATION OF DUAL CREDIT SYSTEM FOR TYPE V-3WA-N

The Dual Credit System as applied to the Wall-O-Matic "200", Type V-3WA-N uses Dual

WALL-O-MATIC, TYPES "V-3WA-N" and "V-3WA-D"

Credit Unit, Type DCU15-L6. It is designed to provide "Single" selections for 5¢ and "EP's" for 10¢.

The principal of operation of the Dual Credit System is identical with that of Type V-3WA-D previously described, however, set-up and resulting selection-credit differs as detailed in the following text.

Figure 6 constitutes a chart condensing information regarding the capabilities and set-up requirements for the three pricing combinations.

Preparation of the system necessitates connecting the Pricing Terminal Board taper tabs corresponding to each panel of desired "EP's" and "SINGLES" for associated pricing. The program must be in panels of 20 selections

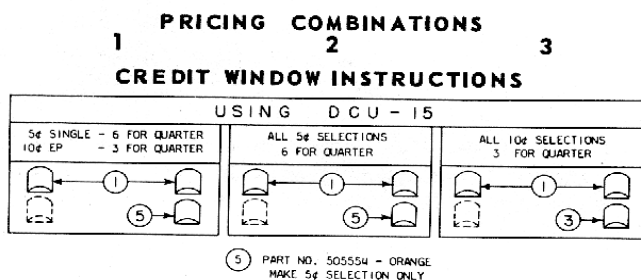

CREDIT WINDOW LIGHT SWITCHBOARD NOT USED

Figure 6.

(10) records, each panel being represented by a number button. "Singles" and "EP's" cannot be in the same panel if there is to be a price difference. *The pricing terminal board on the Tormat Selection Receiver, the pricing terminal board on the Tormat Electrical Selector, and the pricing terminal boards in all Wall-O-Matics MUST be connected to match.*

In pricing combination No. 1 the Pricing Terminal Board is connected for "SINGLES" & "EP's" and the following operational sequence holds true:

1. The deposit of a nickel rotates the credit wheel in the Dual Credit Unit to the one-credit position and the lower right hand credit window lights go on indicating "Make 5¢ Selection Only". Now only "Singles" plays will result when proper selection buttons are pushed. If buttons for "EP" selection are depressed no selection will result unless another nickel is deposited.
2. Another nickel (or a dime initially) rotates the credit wheel to the two-credit position and the upper two credit window lights go on indicating "Make Any Selection".

tion". Credit window lights remain the same as when on the two-credit position, with the deposit of additional coins.

With the Pricing Terminal Board tabs all placed on "Singles" as in pricing combination No. 2, the following holds true:

1. The first nickel deposited rotates the credit wheel to the one-credit position, and lower credit window light goes on indicating "Make 5¢ Selection Only".
2. Another nickel (or a dime initially) rotates the credit wheel to the two-credit position and the upper two credit window lights go on indicating "Make Any Selection". Credit window lights remain the same as when on the two-credit position with the deposit of additional coins.

With the Pricing Terminal Board tabs all placed as indicated in pricing combination No. 3, the following holds true:

1. The Dual Credit Unit operation is similar to that of the previous combination No. 1 however, no plays will result on the first credit position.

Deposit of a nickel will light up the lower right hand credit window and indicate "5¢ Credit-Another Coin Required". This credit window (Part No. 505552) is factory assembled in the lower left hand side of the V-3WA-N Wall-O-Matic cover and must be transposed with "Make 5¢ Selection Only" (Part No. 505554) to satisfy combination No. 3. See Figure 4 for method of assembly.

2. The deposit of another nickel (or dime initially) rotates the credit wheel to the two-credit position and the upper credit lights go on indicating "Make Any Selection".

Appropriate Classification Headings required to satisfy a desired pricing combination may be chosen from the tabulated listing, Figure 7.

CLASSIFICATION HEADING	PART NUMBER	
	5¢ SINGLES	10¢ EP's
HIT TUNES	505901	505916
RHYTHM & BLUES	505902	505917
FOLK & WESTERN	505903	505918
ALL TIME FAVORITES	505904	505919
CLASSICS & VARIETIES	505905	505920

Figure 7.

MAINTENANCE AND SERVICE

CLEANING

The slug rejector should be kept free of dirt and dust. If a rejector has been working successfully and becomes erratic or fails to work at all, the trouble can generally be attributed to dirt or to some stoppage in the coin track. Cleaning only should correct the trouble.

Switch and relay contacts should be cleaned with a contact burnisher. Do not use a file, sandpaper, or emery cloth.

The contacts on the selector disc should be cleaned with a cloth saturated with carbon-tetrachloride. Do not use emery cloth or sandpaper. The contacts are silver plated brass. To sand them or clean them with an abrasive will remove the plating and expose the brass. The brass does not provide good contact and will require more frequent service as well as cause erratic operation. The contacts should not be lubricated.

The contact point on the contact arm should be cleaned with carbon-tet'. It is not necessary to remove it from the shaft. A piece of cloth saturated with carbon-tet' can be drawn under the contact point.

The selector switches and the motor gears should be kept free of dirt and dust by blowing out. Do not use roach powders of any kind. Most of the powders are highly corrosive and will soon cause failure of the switches. If powders have been used, the switches should be thoroughly cleaned.

LUBRICATION

The motor gears should be lubricated with Aero Lubriplate.

A drop or two of Seeburg No. 53014 Special Purpose Oil on the Motor Shaft bearings will reduce wear and friction to a minimum.

The scavenger linkage of the slug rejector can be sparingly lubricated with No. 105 Lubriplate at wear and friction points, but care should be taken so that it does not get into the coin track. Oil should not be used. The coin path of the rejector may be dusted with Motor Mica.

MOTOR

The motor is designed to operate the Wall-O-Matic through a complete cycle in a little more

than 2 seconds. If the motor is slow, the current impulses to the step relay (in the Selection Receiver) will be slow and cause erratic operation of the step switch assembly. The motor can best be checked for speed by allowing it to operate steadily and counting the turns per minute of the contact arm. Normal speed is 19 revolutions per minute. Acceptable speed limits are 17 to 21 rpm. If the motor is slow, check for binding or excessive friction. If the motor runs slow when there are no binds, it will have to be replaced.

COIN SWITCHES

If operation of the coin switches is erratic, the slug rejector must first be removed and then the coin switch contacts carefully cleaned with carbon tetrachloride using a No. 2 camel hair brush. Burnish the contacts by inserting a burnishing tool between them. *Never use a file or sandpaper for contact cleaning.*

Adjustment of the coin switches is shown in Figure 8.

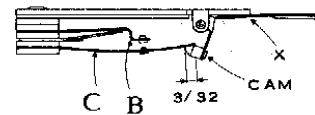

Figure 8.

- A. Adjust the coin levers so they are parallel with the bottom edge of the rejector when bearing against switch bracket at "X".
- B. Adjust short blade and bracer for 1/32" to 3/64" contact gap (all switches) with short blade bearing against tip of bracer approximately 1 to 3 grams (measured at contact point).
- C. Adjust the long blade so it bears against the cam, as measured at the switch contact.
 1. Nickel switch (front) - 8 to 10 grams
 2. Dime switch (middle) - 6 to 8 grams
 3. Quarter switch (back) - 8 to 10 grams
- D. Adjust the switch actuating cams to be tilted as shown and overlap the switch blade approximately 3/32".

WALL-O-MATIC, TYPES "V-3WA-N" and "V-3WA-D"

CONTACT ARM POSITION

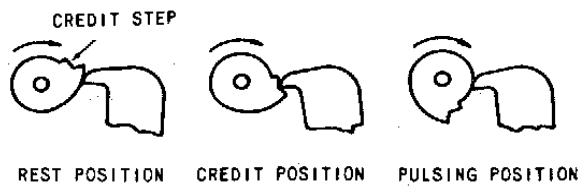

Figure 9. Cam Positions

1. Turn the motor manually until the latch bar lever drops to the credit step of the outer cam and then reverse the direction until the point of the lever is against the vertical part of the cam as shown in *Figure 9* above.

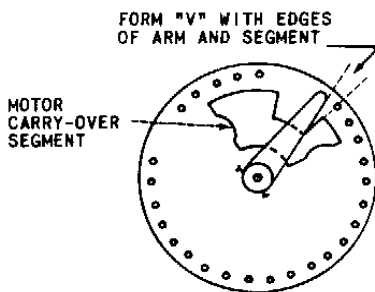

Figure 10.

2. Set the Contact Arm on the shaft so the edge of the blade forms a "V" with the edge of the motor carry-over segment as shown in *Figure 10*, and the lower part of the hub is spaced approximately 1/8" from the surface of the selector plate as shown in *Figure 11*.

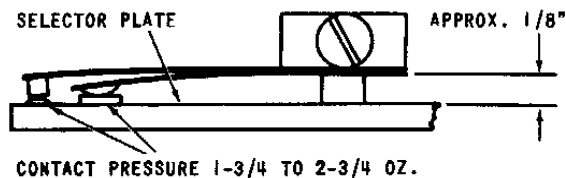

Figure 11.

LATCH BAR ADJUSTMENT

The selection switches have three conditions of operation corresponding to the 3-positions of the cam shown in *Figure 9* and are

operated by the cam through mechanical linkage. In the stand-by positions the switch latch bars are held against the pressure of the latch bar spring so the selector buttons are free to move in and out and will not stay in the pressed-in position. In the credit position the bars are released to a position which permits a selection switch, when pressed, to latch in the operated position but, if another switch is operated, the first will be released. In the cycling position the latch bars are fully released so the selection switches are locked in either the normal or pressed positions.

The adjustment for the latch bar operation is made with the screws – one for each selection switch assembly – at the right of the assemblies (*shown in Figure 12*) in the following manner:

1. Place the cam in the Credit Position (*Figure 9*).
2. Turn the adjusting screws until the selection switch shafts strike the latch bars, but do not latch in the pressed-in position.
3. Back out the screws 1/2 to 3/4 turn.
4. Check for positive locking of the switches when the cam is in Cycling "position".
5. Check for full release and free in-and out movement of the switches when the cam is in stand-by position.

SELECTION SWITCH ASSEMBLIES

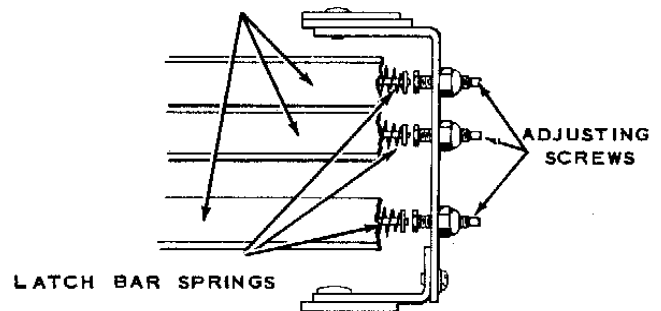
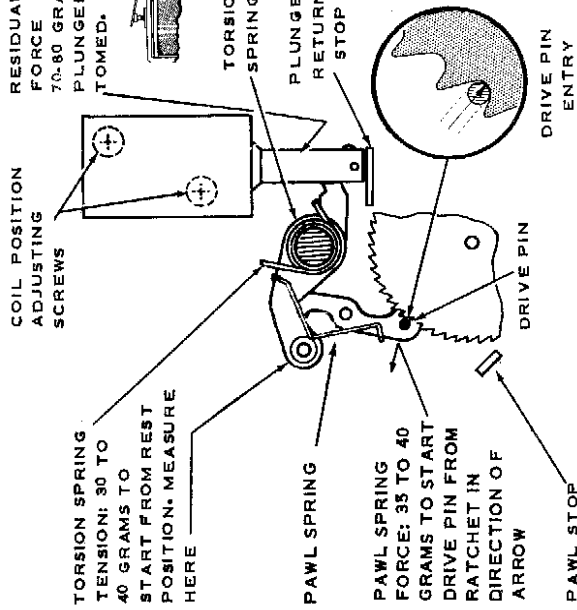

Figure 12.

ADD 6 (25¢) DRIVE ADJUSTMENT



- A. With wheel stop against stop pin, adjust stop pin position so ADD 6 drive pin enters ratchet without striking or rubbing the sides of the teeth.
- B. Loosen the two screws holding the coil.
- C. Operate the plunger manually by applying force at the end of the plunger (*not the levers*) so it is fully seated.
- D. Position the coil so the plunger operation will move the wheel six teeth and be fully detented. Tighten screws holding the coil.
- E. Adjust pawl stop for minimum play in wheel when plunger is fully seated.
- F. Adjust plunger return stop position for clearance between the drive pin and the tips of the ratchet teeth. The tips should pass without rubbing but the clearance must not be more than .010".

ADD 2 (10¢) DRIVE ADJUSTMENT

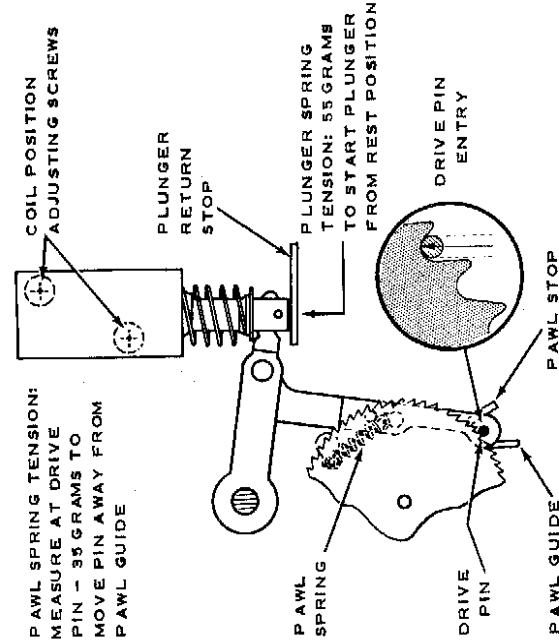

- A. Adjust pawl guide so drive pin enters ratchet without striking or rubbing the sides of the teeth.
- B. Loosen the two screws holding the coil.
- C. Operate the plunger manually by applying force at the end of the plunger (*not the levers*) so it is fully seated.
- D. Position the coil so the plunger operation will move the wheel two teeth and be fully detented. Tighten screws holding the coil.
- E. Adjust pawl stop for minimum play in wheel when plunger is fully seated.
- F. Adjust plunger return stop position for clearance between the drive pin and the tips of the ratchet teeth. The tips should pass without rubbing but the clearance must not be more than .010".

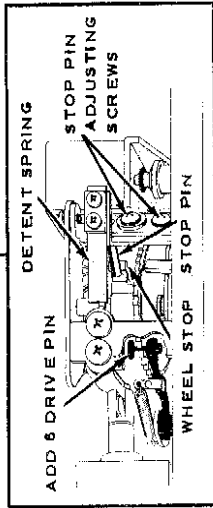

WHEEL STOP AND DETENT ADJUSTMENT

- A. With wheel stop against stop pin, adjust stop pin position so ADD 6 drive pin enters ratchet without striking or rubbing the sides of the teeth.
Entry of all drive pins and the detent spring position adjustments are effected by the stop pin position and should be checked if a change is made.
- B. Adjust position and force of detent spring so roller is *in full detent* when wheel stop is against stop pin and roller pressure against wheel is 150 to 160 grams ($\frac{1}{2}$ oz.).

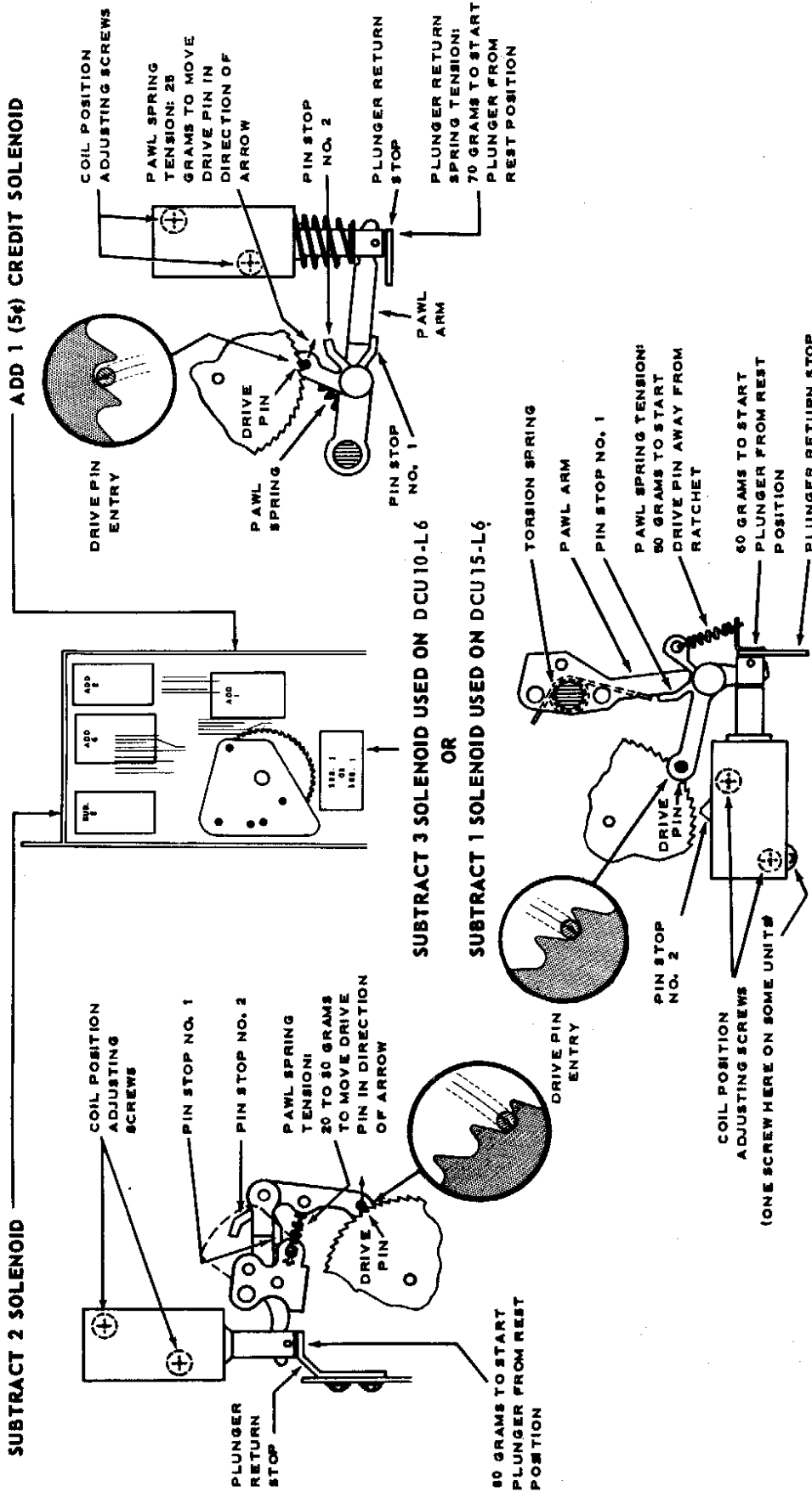

- A. Adjust pin stop No. 1 so the drive pin enters the ratchet without striking or rubbing the sides of the teeth.
- B. Adjust the plunger return stop position for clearance between the drive pin and the tips of the ratchet teeth. The tips should pass without rubbing but the clearance must not be more than .010".
- C. Loosen the two screws holding the coil.
- D. Operate the plunger manually by applying force at the end of the plunger (*not the levers*) so it is fully seated.
- E. Position the coil so the plunger operation will move the wheel the required number of teeth and will be in full detent. Tighten screws holding the coil.
- F. Adjust pin stop No. 2 for minimum play in wheel when plunger is fully seated.

WALL-O-MATIC "200", TYPE V-3WA

CONTACT OPERATION & GAP ADJUSTMENT

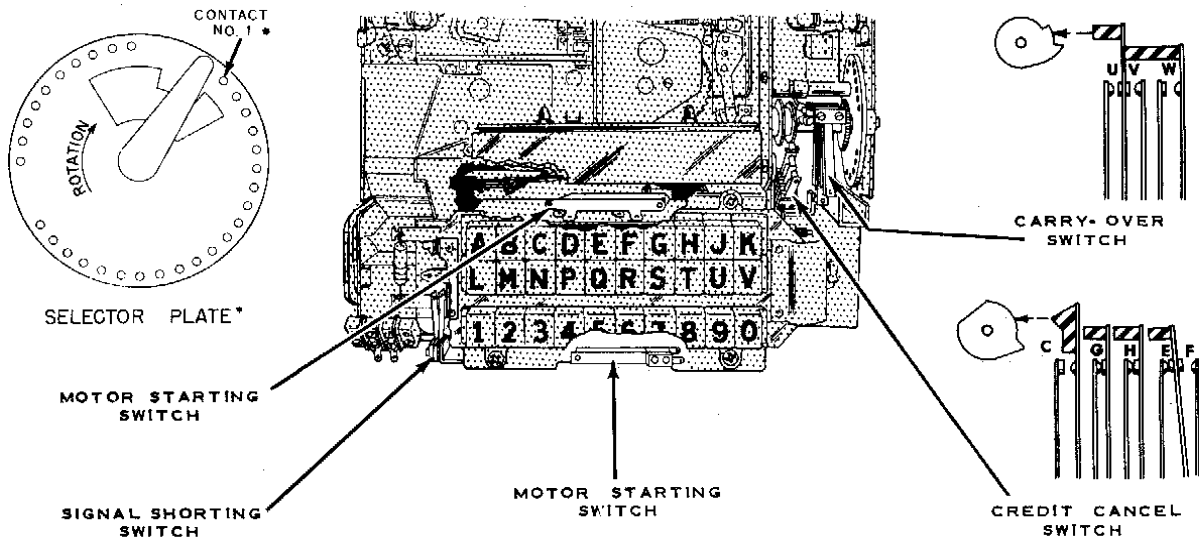

CONTACT	STAND- BY	CREDIT POSITION	CYCLING (CREDIT- CANCEL)
CARRY- OVER SWITCH			
U	Open 1/16	Open – Minimum Gap 1/64	Closed
V	Closed	Open – Minimum Gap 1/64	Open 1/16
W	Open 1/16	Open – Minimum Gap 1/64	Closed
CREDIT CANCEL SWITCH			
C	Open 1/16	Open 1/16	* Closed While Contact Arm Moves From Contact Nos. 3 or 4 to Nos. 23 or 24.
G	Closed	Closed	* Open 1/16 While Contact Arm Moves From Contact No. 25 to 28.
H	Closed	Closed	* Open 1/16 While Contact Arm Moves From Contact No. 25 to 28.
E	Closed	Closed	* Open 1/16 While Contact Arm Moves From Contacts 25 to 28. †
F	Open 1/16	Open 1/16	* Closed While Contact Arm Moves From Contact No. 26 to 27. †
MOTOR STARTING SWITCHES			
R	The Motor Starting Switches Should Make Contact At The Bottom Of The Selection Button Stroke. They Should Make Contact As Close As Possible To The Bottom and Still Maintain Contact When Any Button On The Switch Is Latched In.		
P			
SIGNAL SHORTING SWITCH			
Y	Contacts Must Close When Any Selection Button Is Pressed Approximately Half Way To The Latched Position . They Must Be Open When The Buttons Are In Latched Or Released Positions.		

* SELECTOR PLATE – Contacts Numbered Clockwise.

† CAUTION: Contact "E" Must Open Before Contact "F" Closes.

WALL-O-MATIC "200", TYPE V-3WA

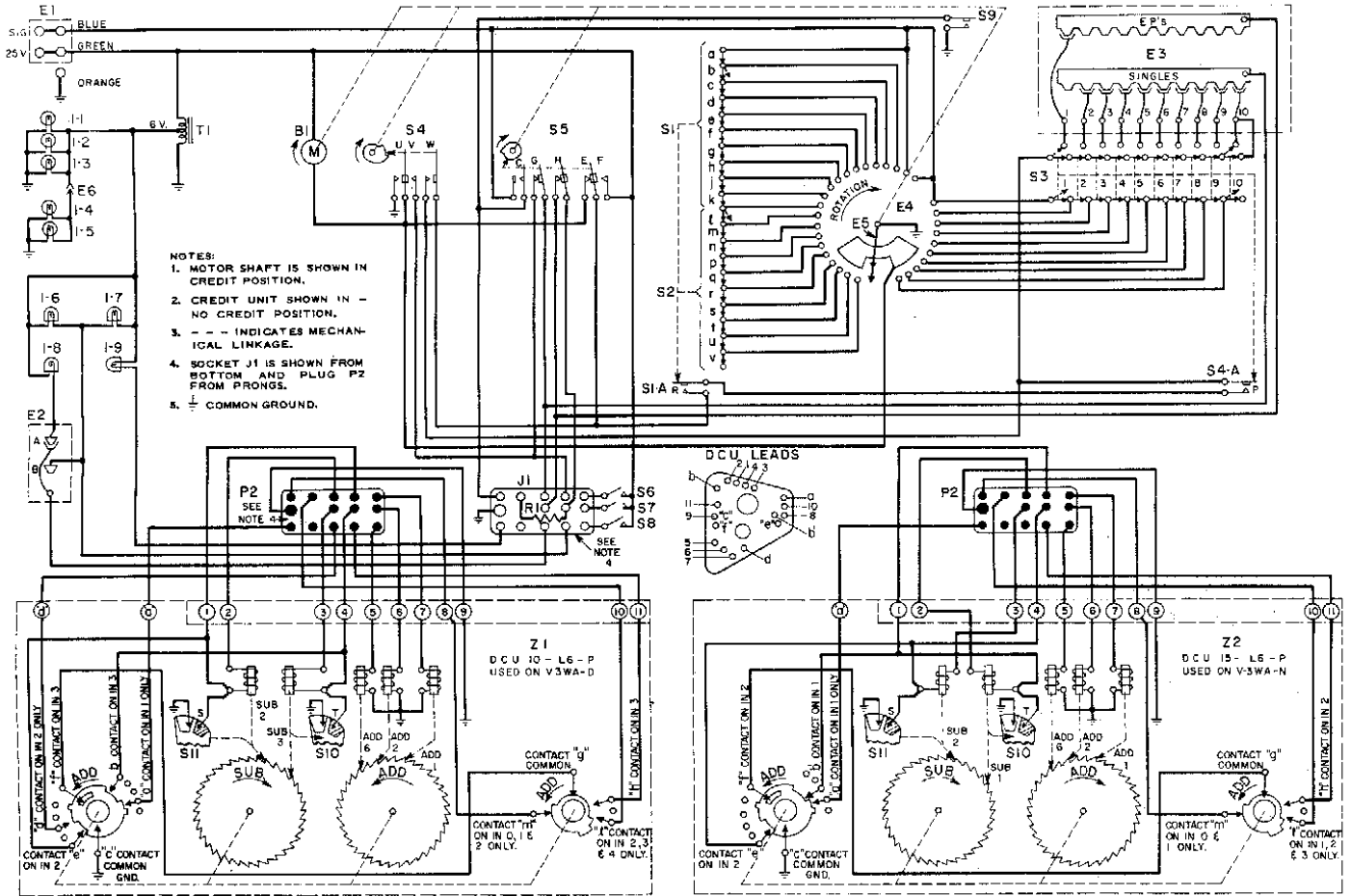

PARTS LIST

Item	Part No.	Part Name	Item	Part No.	Part Name
B1	505595	Motor Assembly	R1	82746	1000 Ohm ± 10% 1 Watt
E1	13398	Terminal Strip	S1	505511	Selector Switch (Top)
E2	505821	Credit Light Terminal Board	S1A		Treadle Bar Starting Switch
E3	410706	Pricing Board	S2	505512	Selector Switch (Middle)
E4	505802	Selector Plate Assembly	S3	505513	Selector Switch (Bottom)
E5	505806	Contact Wiper Arm	S3A		Treadle Bar Starting Switch
E6	504045	Brush Assembly	S4	505800	Carry-Over Switch
I1	505173	No. 55 G. E. Lamp	S5	505794	Credit Cancel Switch
I2	505173	No. 55 G. E. Lamp	S6	505795	5¢ Coin Switch
I3	505173	No. 55 G. E. Lamp	S7		10¢ Coin Switch
I4	10242	No. 51 G. E. Lamp	S8		25¢ Coin Switch
I5	10242	No. 51 G. E. Lamp	S9	505813	Signal Shorting Switch
I6	10242	No. 51 G. E. Lamp	S10		Carry-Over Switch
I7	10242	No. 51 G. E. Lamp	S11		Carry-Over Switch
I8	10242	No. 51 G. E. Lamp	T1	505796	Transformer
I9	10242	No. 51 G. E. Lamp	Z1	450010	Dual Credit Unit (DCU10-L6)
J1	306014	Socket		450415	Dual Credit Unit (DCU10-L6P)
P2	125632	Plug & Shell Assembly	Z2	450417	Dual Credit Unit (DCU15-L6P)

WALL-O-MATIC "200", TYPE V-3WA

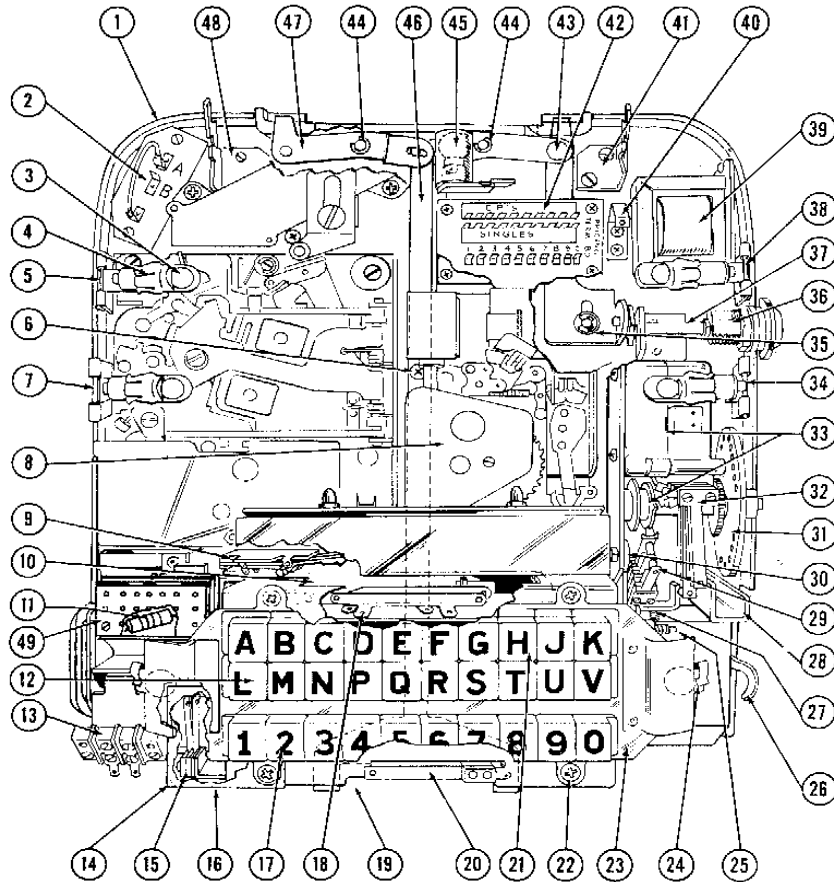

Back Plate

PARTS LIST

Item	Part No.	Part Name	Item	Part No.	Part Name
1	505515	BACK PLATE ASSEMBLY (COMPLETE)	28	505763	CABLE GUARD
	505516	BACK PLATE & STUD ASSEMBLY	29	505794	CREDIT CANCEL SWITCH ASSEMBLY
	505929	BACK PLATE ASSEMBLY (COMPLETE)		505793	CREDIT CANCEL SWITCH BRACKET
	505983	BACK PLATE ASSEMBLY (COMPLETE)		505762	SPRING ANCHOR
	505928	BACK PLATE & STUD ASSEMBLY		912725	SEMS
2	505822	TERMINAL BOARD ASSEMBLY	30	505287	SHOULDER SCREW
	10242	NO. 51 GE LAMP		925523	1210 LOCKWASHER
4	505589	LIGHT SHIELD		902360	10-32 HEX NUT
5	505745	BRACKET AND LIGHT ASSEMBLY	31	505802	SELECTOR PLATE ASSEMBLY
6	914048	SEMS (DCU MOUNTING)		505806	CONTACT WIPER ARM ASSEMBLY
7	505743	BRACKET AND LIGHT ASSEMBLY	32	505800	CARRY-OVER SWITCH
8	450010	DCU 10-L6		400597	TENSION PLATE
	505823	CREDIT UNIT SHIELD		912652	SEMS
	914048	SEMS	33	505595	MOTOR ASSEMBLY
	450417	DCU 15-L6-P	34	505744	BRACKET AND LIGHT ASSEMBLY
	450415	DCU 10-L6-P		505749	BRACKET & LIGHT ASSEMBLY
9	505795	COIN SWITCH	35	405203	RETAINING RING
10	505811	UPPER SHIELD (SELECTOR SWITCH)		921553	FLAT WASHER
	912832	6-32 X 1/8 PHILLIPS B.H.M.S.	36	505590	LOCK ASSEMBLY
11	82746	RESISTOR - 1000 OHMS ± 10% 1 W.		505592	PLUG AND BARREL
12	505512	SELECTOR SWITCHES (L-V) (CENTER) (NOT SHOWN)		905201	NUT (MOUNTING)
13	13398	TERMINAL STRIP		505591	KNURLED PIN
	505798	INSULATION	37	505807	LOCK SHAFT, DISC AND STUD ASSEM.
	913300	6/32 X 1/2 B.H.M.S.	38	505746	BRACKET AND LIGHT ASSEMBLY
14	505835	GUARD STRIP	39	505796	TRANSFORMER
15	505813	SIGNAL SHORTING SWITCH	40	504045	BRUSH ASSEMBLY
	912491	5-40 X 1/2 PHILLIPS B.H.M.S.		912395	SEMS
	400597	TENSION PLATE	41	505775	R. H. PROGRAM HOLDER SUPPORT ASSEMBLY
16	505799	BOTTOM HOLE COVER (NOT SHOWN)	42	410706	PRICING BOARD
17	505537	PUSH BUTTON - NUMERALS	43	505809	UPPER LOCK PAWL ASSEMBLY
18	505511	SELECTOR SWITCHES TOP (MOTOR STARTING SWITCH) (A-K)	44	J-22021	"C" WASHER
19	505812	LOWER SHIELD (SELECTION SWITCH) (NOT SHOWN)	45	505876	CARDBOARD TUBE
20	505513	SELECTOR SWITCH - LOWER (MOTOR STARTING SWITCH)		505739	PROGRAM LIGHT BRACKET ASSEM.
21	505536	PUSH BUTTON - LETTER		505173	NO. 55 GE LAMP
22	912945	6-32 X 1/4 PHILLIPS B.H.M.S.	46	505810	LOWER LOCK BAR ASSEMBLY
23	505804	BUTTON LIGHTING PLATE ASSEMBLY	47	505753	UPPER LOCK PAWL
24	505121	LIGHT SOCKET ASSEMBLY	48	505776	L. H. PROGRAM HOLDER SUPPORT ASSEMBLY
	505173	NO. 55 GE LAMP	49	912858	SEMS
25	505587	LATCH BAR LEVER ASSEMBLY		505981	BRACKET & SOCKET ASSEMBLY
26	505767	COIN BOX ASSEMBLY		306014	SOCKET - 14 - CONNECTOR
27	505792	LATCH BAR PAWL		505980	BRACKET
	400161	SPRING		980780	1/8 X 9/32 TUB. RIVETS
				912882	SEMS

* USED WITH TYPE V-3WA-N

† USED WITH TYPE V-3WA-D

WALL-O-MATIC "200", TYPE V-3WA

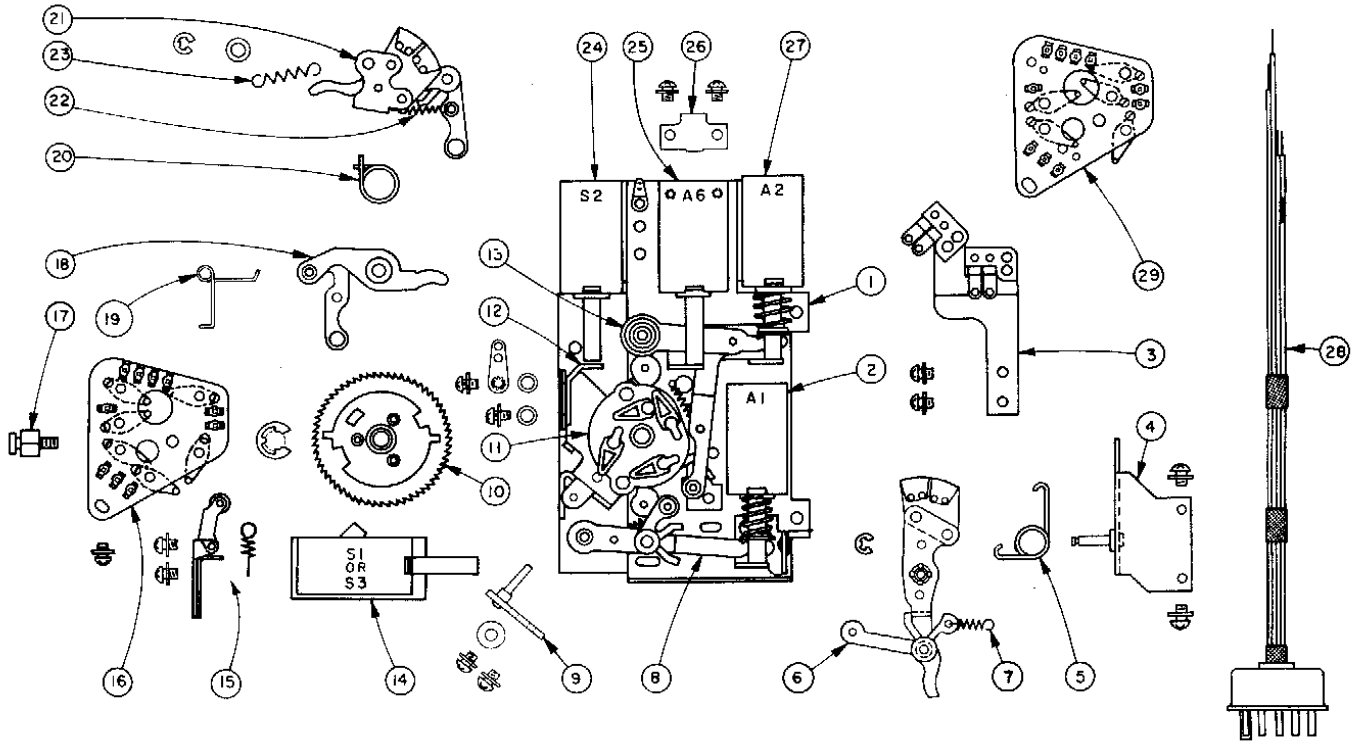

Dual Credit Unit Assemblies

PARTS LIST

Item	Part No.	Part Name	Item	Part No.	Part Name
	450010	TYPE DCU 10-L6	†	450350	COIL & BRACKET ASSEM. (SUB 1)
	450014	TYPE DCU 15-L6	†	450348	SOLENOID PLUNGER ASSEM.
	450415	TYPE DCU 10-L6-P	†	450075	SOLENOID PLUNGER ASSEM.
	450417	TYPE DCU 15-L6-P	920741	920741	FLAT WASHER
1	450021	MOUNTING PLATE RIVETED ASSEM.	15	450296	DETENT SPRING & ROLLER ASSEM.
2	450192	COIL & BRACKET ASSEM. (ADD 1)		450358	DETENT GUARD
	450075	SOLENOID PLUNGER ASSEMBLY		910821	3-48 X 3/16 PHILLIPS P.H.M.S.
	450076	SPRING	16	* 450141	CONTACT PLATE ASSEM.
	912882	SEMS		912859	SEMS
	125452	RETAINING RING	†	450356	CONTACT PLATE ASSEMBLY
	920741	FLAT WASHER	17	450273	STUD
3	450146	SWITCH (CARRYOVER) ASSEM.	18	450121	CREDIT ARM ASSEM. (ADD 6)
	912859	SEMS	19	450131	SPRING (TORSION)
4	* 450037	PIVOT ARM BRACKET ASSEM.	20	450130	SPRING (TORSION)
	912882	SEMS	21	450276	CANCEL ARM ASSEM. (SUB 2)
	† 450332	PIVOT ARM BRACKET ASSEM.	22	450096	SPRING
5	450323	SPRING (TORSION)		125448	RETAINING RING
6	* 450109	CANCEL ARM ASSEM. (SUB 3)		921112	FLAT WASHER
	125448	RETAINING RING	23	245773	SPRING
7	† 450351	CANCEL ARM ASSEMBLY (SUB 1)	24	450200	CANCEL COIL & BRACKET ASSEM. (SUB 2)
	450129	SPRING		920741	FLAT WASHER
8	450085	CREDIT ARM ASSEM. (ADD 1)		912882	SEMS
	450096	SPRING		450075	SOLENOID PLUNGER ASSEM.
9	125448	RETAINING RING	25	450198	CREDIT COIL & BRACKET ASSEM. (ADD 6)
	450326	STOP PIN PLATE ASSEM.		920741	FLAT WASHER
	920739	FLAT WASHER		912882	SEMS
	912968	SEMS		450074	SOLENOID PLUNGER ASSEM.
10	450078	CREDIT WHEEL ASSEM.		450318	RESIDUAL SPRING
	125403	RETAINING RING	26	450318	RESIDUAL SPRING
11	450284	TERMINAL BOARD ASSEM.		912810	6-32 X 1/8 PHILLIPS R.H.M.S.
12	450102	SOLENOID STOP BRACKET	27	450196	COIL & BRACKET ASSEM. (ADD 2)
	940761	TERMINAL LUG		912882	SEMS
	920741	FLAT WASHER		920741	FLAT WASHER
	912859	SEMS		450329	SPRING
13	450111	CREDIT ARM ASSEMBLY (ADD 2)		450075	SOLENOID PLUNGER ASSEM.
	450096	SPRING	28	450402	PLUG & CABLE ASSEM. (DCU 10-L6-P)
	125448	RETAINING RING		450401	PLUG & CABLE ASSEM. (DCU 15-L6-P)
14	* 450194	COIL & BRACKET ASSEM. (SUB 3)		125632	PLUG
	912882	SEMS			

* USED ON TYPE DCU 10-L6 AND DCU 10-L6-P

† USED ON TYPE DCU 15-L6 AND DCU 15-L6-P

WALL-O-MATIC "200", TYPE V-3WA

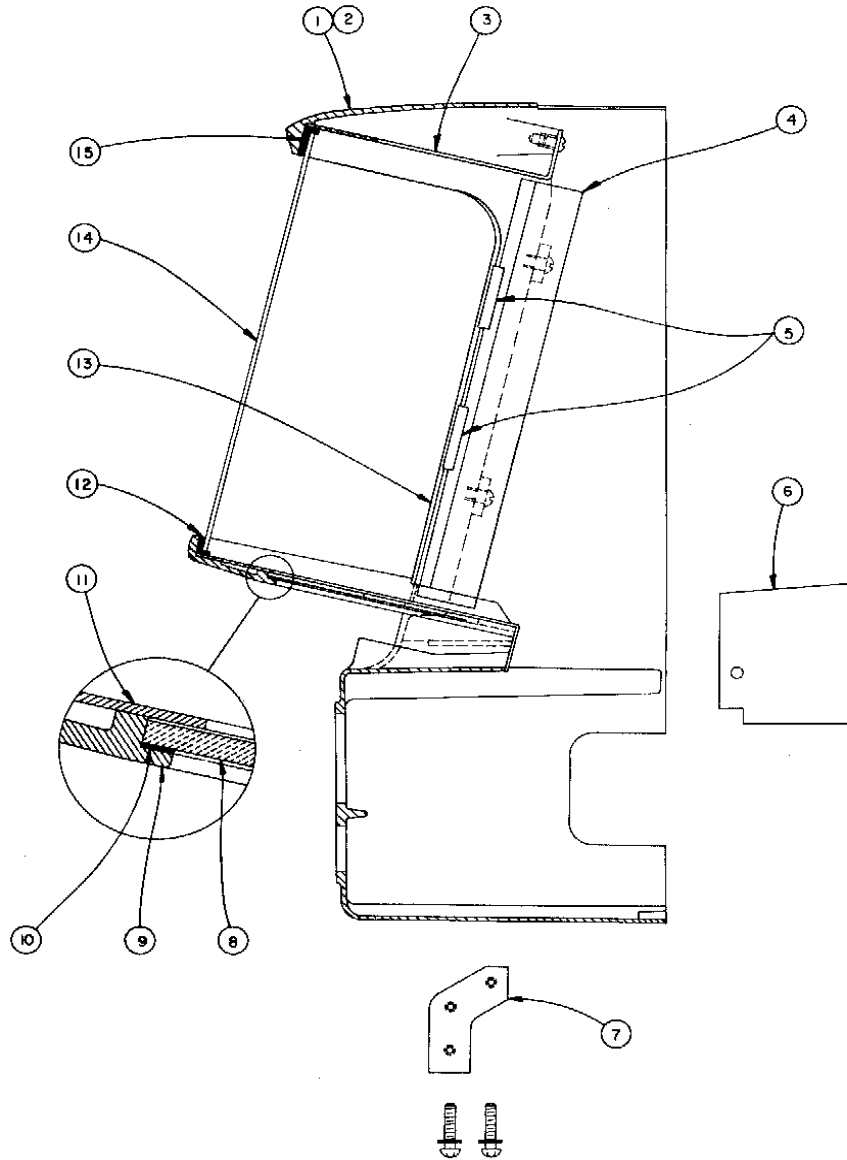

Housing Assembly

PARTS LIST

Item	Part No.	Part Name	Item	Part No.	Part Name
1	505682	Housing Assembly (Complete)	505553		Selector Window (Red) (10¢ Credit) Lower Left (Optional)
2	505683	Housing (Riveted Assembly Only)	6	505741	Light Shield
3	505686	Top Wall (Housing)	7	505684	Program Base Retainer Plate
	9 15373	Sems		914669	Sems
4	505584	Window Retainer (Casting) R. H.	8	505691	Instruction Window Assembly
	505585	Window Retainer (Casting) L. H.	9	505541	Program Base (Casting)
	9 15548	Sems	10	53419	Rubber Adhesive
5	505550	Selector Window (Green) (Any Selection) Top	11	505715	Instruction Plate
	505551	Selector Window (Amber) (10¢ Only) Lower Left	12	505768	Program Window Gasket (Bottom)
	505552	Selector Window (Red) (5¢ Credit) Lower Right	13	505687	Program Window Gasket (Sides)
	505616	Diffuser	14	505680	Program Window
	903060	Push Nut	15	505688	Program Window Gasket (Top)

WALL-O-MATIC "200", TYPE V-3WA

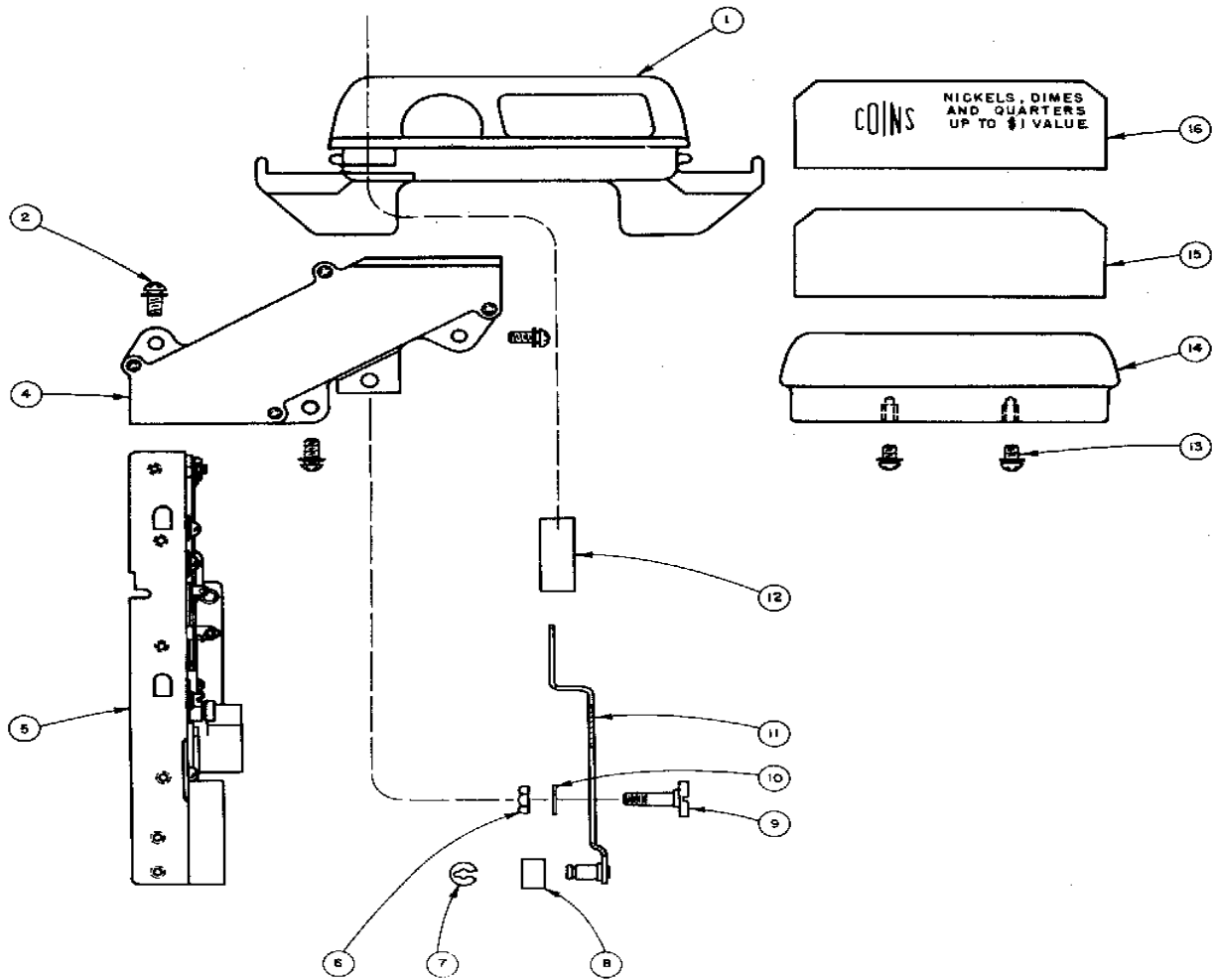

Coin Equipment

PARTS LIST

Item	Part No.	Part Name
1	505580	Drop Slot (Front)
2	914372	8-32 x 3/8 Sems Fastener
4	505815	Coin Chute
5	401373	Slug Rejector
6	902360	10-32 Hex Nut
7	J-22021	"C" Washer
8	505819	Ejector Slide Roller
9	505820	Slide Shoulder Screw
10	925523	1210 Lockwasher
11	505816	Ejector Slide & Stud Assembly
12	504069	Push Button
13	914133	8-32 x 1/4 Sems Fastener
14	505581	Drop Slot Back
15	505759	Window Backing
16	505758	Drop Slot Window

WALL-O-MATIC "200", TYPE V-3WA

PARTS LIST

Item	Part No.	Part Name	Item	Part No.	Part Name
1	9 12858	Sens	20	505659	Program Holder Leaf No. 0 (Complete)
2	505613	Program Light Socket and Bracket Assembly		505639	Number Strip (L9-V9)
3	10242	No. 51 Lamp		505630	Number Strip (A0-K0)
4	9 14145	Sens		505669	Program Leaf Assembly No. 0
5	505605	Program Holder Assembly (Complete)	21	505779	Hit Tunes - 10¢ Singles (V-3WA-D)
6	505612	Program Light Reflector		505901	Hit Tunes - 5¢ Singles (V-3WA-N)
7	905299	Speed Nut	22	505655	Program Holder Leaf No. 1 (Complete)
8	9 20461	Washer		505632	Number Strip (L2-V2)
9	505647	Spacer Sleeve		505621	Number Strip (A1-K1)
10	505648	Program Leaf Spring		505665	Program Leaf Assembly No. 1
11	505649	Short Sleeve	23	505656	Program Holder Leaf No. 7 (Complete)
12	505650	Program Leaf Hinge Pin		505631	Number Strip (L1-V1)
13	505606	Program Holder Back Plate Assembly		505627	Number Strip (A7-K7)
	505626	Number Strip (A6-K6)		505666	Program Leaf Assembly No. 7
	505640	Number Strip (L0-V0)	24	505843	All Time Favorites 15¢ EP (V-3WA-D)
14	505651	Program Holder Leaf No. 5 (Complete)		505919	All Time Favorites - 10¢ EP (V-3WA-N)
	505636	Number Strip (L6-V6)	25	505657	Program Holder Leaf No. 8 (Complete)
	505625	Number Strip (A5-K5)		505637	Number Strip (L7-V7)
	505661	Program Leaf Assembly No. 5		505628	Number Strip (A8-K8)
15	505781	Folk and Western 10¢ Singles (V-3WA-D)		505667	Program Leaf Assembly No. 8
	505903	Folk & Western - 5¢ Singles (V-3WA-N)	26	505658	Program Holder Leaf No. 9 (Complete)
16	505652	Program Holder Leaf No. 4 (Complete)		505638	Number Strip (L8-V8)
	505635	Number Strip (L5-V5)		505629	Number Strip (A9-K9)
	505624	Number Strip (A4-K4)		505668	Program Leaf Assembly No. 9
	505662	Program Leaf Assembly No. 4	27	505844	Classics and Varieties 15¢ EP (V-3WA-D)
17	505780	Rhythm & Blues 10¢ Singles (V-3WA-D)		505920	Classics & Varieties - 10¢ EP (V-3WA-N)
	505902	Rhythm & Blues - 5¢ Singles (V-3WA-N)			
18	505653	Program Holder Leaf No. 3 (Complete)			
	505634	Number Strip (L4-V4)			
	505623	Number Strip (A3-K3)			
	505663	Program Leaf Assembly No. 3	<u>Optional</u>	505782	All Time Favorites 10¢ Singles
19	505654	Program Holder Leaf No. 2 (Complete)		505783	Classics & Varieties 10¢ Singles
	505633	Number Strip (L3-V3)		505840	Hit Tunes 15¢ EP
	505622	Number Strip (A2-K2)		505841	Rhythm & Blues 15¢ EP
	505664	Program Leaf Assembly No. 2		505842	Folk & Western 15¢ EP