

# **SEEBURG**

**TORMAT SELECTOR RECEIVER**

**Types**

**TSR1-L6 / TSR2-L6 / TSR3-L6 / TSR4-L6  
&  
TSR3 / TSR4 Code B**



## TORMAT SELECTION RECEIVER TYPE TSR1-L6

The Tormat Selection Receiver, Type TSR1-L6 is the power distribution and control center for operation of the Select-O-Matic mechanism and the Tormat Memory System from the Electrical Selector at the phonograph or by remote control with 200-selection, 3-wire, Wall-O-Matics. Power enters the Receiver through the line cord and main switch and is distributed, at 117 volts or through transformers, to the Electrical Selector, the Select-O-Matic Mechanism, cabinet lighting, program selector, amplifier and the Wall-O-Matics. All connections to the Receiver are made with plugs and connectors of different types and sizes to avoid possibility of incorrect connections.

Included in the Receiver are a Step Switch and Relay Assembly, a Dual Credit Unit and a pulse amplifier unit. The Step Switch and Relay Assembly and a 2D21 thyratron, V6, are for step relay operation for selection from the Wall-O-Matics. The Dual Credit Unit incorporates an accumulative add-and-subtract credit switch for credit and selection control at the phonograph. The pulse amplifier includes a 12AX7 tube, V1, that amplifies the trip signal from the

output loop of the Tormat Memory Unit on the Select-O-Matic Mechanism. The pulse from the 12AX7 tube controls a 2D21 thyratron, V2, which in turn passes current for operation of the trip solenoid of the Select-O-Matic mechanism.

A 2D21, V3, operates as a relay to control read-out current pulse for the Tormat Memory Unit. Another 2D21, V7, controls the Tormat write-in pulse. A 6X4 rectifier tube, V4, supplies grounded-positive plate power for the 12AX7 pulse amplifier and, with an OA2 regulator tube, V5, regulated voltage supply for grid bias of V3 and V7. The regulated supply is also used for charging condensers from which are taken power for the write-in and read-out pulses.

A full wave selenium rectifier supplies d.c. at approximately 25 volts for some of the relays of the Step Switch Assembly and a timing relay in the Dual Credit Unit and for grid bias of the 2D21 tubes for the trip solenoid and step relays.

All of the mechanism control circuits, plate and bias supplies and tube heater circuits are supplied from the multiple-secondary transformer, T1.

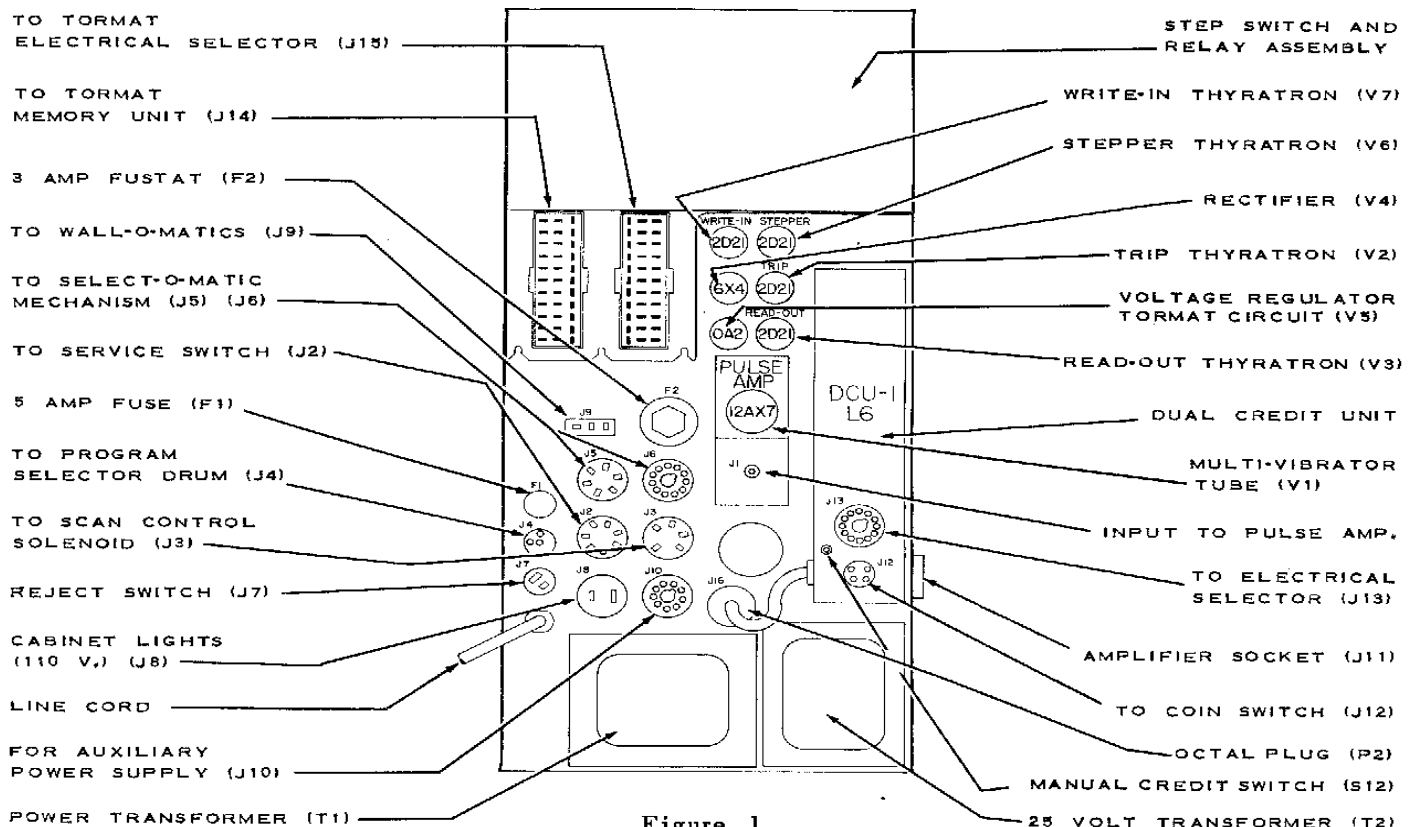

Figure 1.

## TORMAT SELECTION RECEIVER, TYPE TSRI-L6

The Dual Credit Unit and the pulse amplifier connect to the circuits of the Receiver with plugs and sockets. They may be removed for test or service. Access to the interior wiring of the Receiver is had, while it is operating in normal position, by removing the cover plate on the outside of the rear door of the phonograph. To remove the cover plate, take off the three wing-nuts located inside the door just above the amplifier and selection receiver and loosen the screw at the center of the bottom edge of the plate. After removing the nuts, pull out on

the plate so the three bolts are out of the holes in the door and lift up on the plate to disengage it at the lower edge.

The Selection Receiver may be removed from its mounting by removing the cover plate and loosening the four screws holding the flanges of the unit. With the four screws loosened, slide the unit away from the amplifier to disengage the locating pins and amplifier socket connection. It may then be lifted from the mounting frame.

## DUAL CREDIT UNIT, TYPE DCU1-L6

The Dual Credit Unit is part of the Tormat Memory System for making selections for coins deposited at the phonograph. It includes three credit solenoids, two subtract solenoids, an add-and-subtract credit switch, a timing relay and two switch groups that are operated by the subtract solenoids. Connections between the Unit and the Selection Receiver are made with an octal plug. Three coin switches in the phonograph connect through a 4-prong socket and a 12-prong socket is for connection to the Electrical Selector.

the switch clockwise with pawls that engage the front ratchet. One of the subtract solenoids operates each time a selection is made. The subtract-2 solenoid turns the credit switch two credit units toward the off position. The subtract-3 solenoid turns it three credit units toward off. Whether the subtract-2 or-3 solenoid operates for a particular selection is determined by the arrangement of connections at the pricing terminal board in the Electrical Selector.

The credit switch is a rotary, wafer type having two switch sections and two ratchets. The credit solenoids add credits by driving the switch counter-clockwise with pawls that engage the back ratchet when the solenoids are energized. The credit solenoids are energized through the nickel, dime and quarter coin switches (in the phonograph cabinet) and add, respectively, one, two and six credit units. A total of twenty-four credit units may be accumulated.

The switch contacts A, B, C, D, E, K and M close when the subtract-3 solenoid operates; contacts F, G, H, I, J, L and N are closed by the subtract-2 solenoid. A and B are carry-over contacts for the subtract-3 solenoid and insure a full operating stroke of the solenoid plunger. F and G are carry-over contacts for the subtract-2 solenoid. Closing H or C energizes the timing relay. Closing D or I energizes the scan control solenoid on the Select-O-Matic mechanism. E completes the counter circuit that totals the 3-credit-unit selections; J completes the circuit to the 2-credit-unit counter. M and N are carry-over contacts for the latch bar solenoid in the Electrical Selector.

### Operation of either subtract solenoid drives

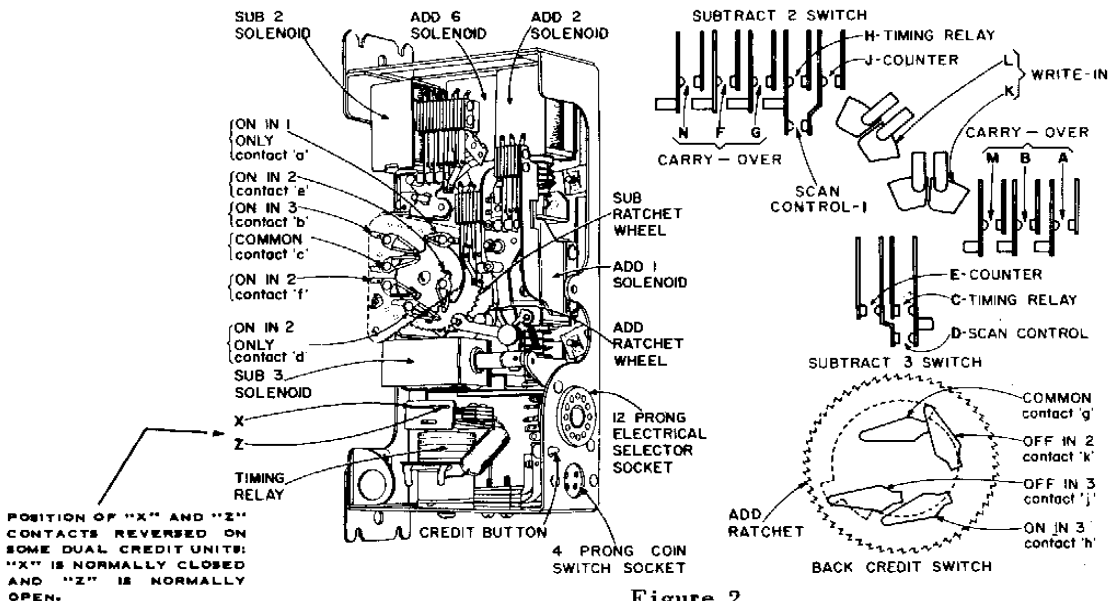

Figure 2.

TORMAT SELECTION RECEIVER, TYPE TSRI-L6

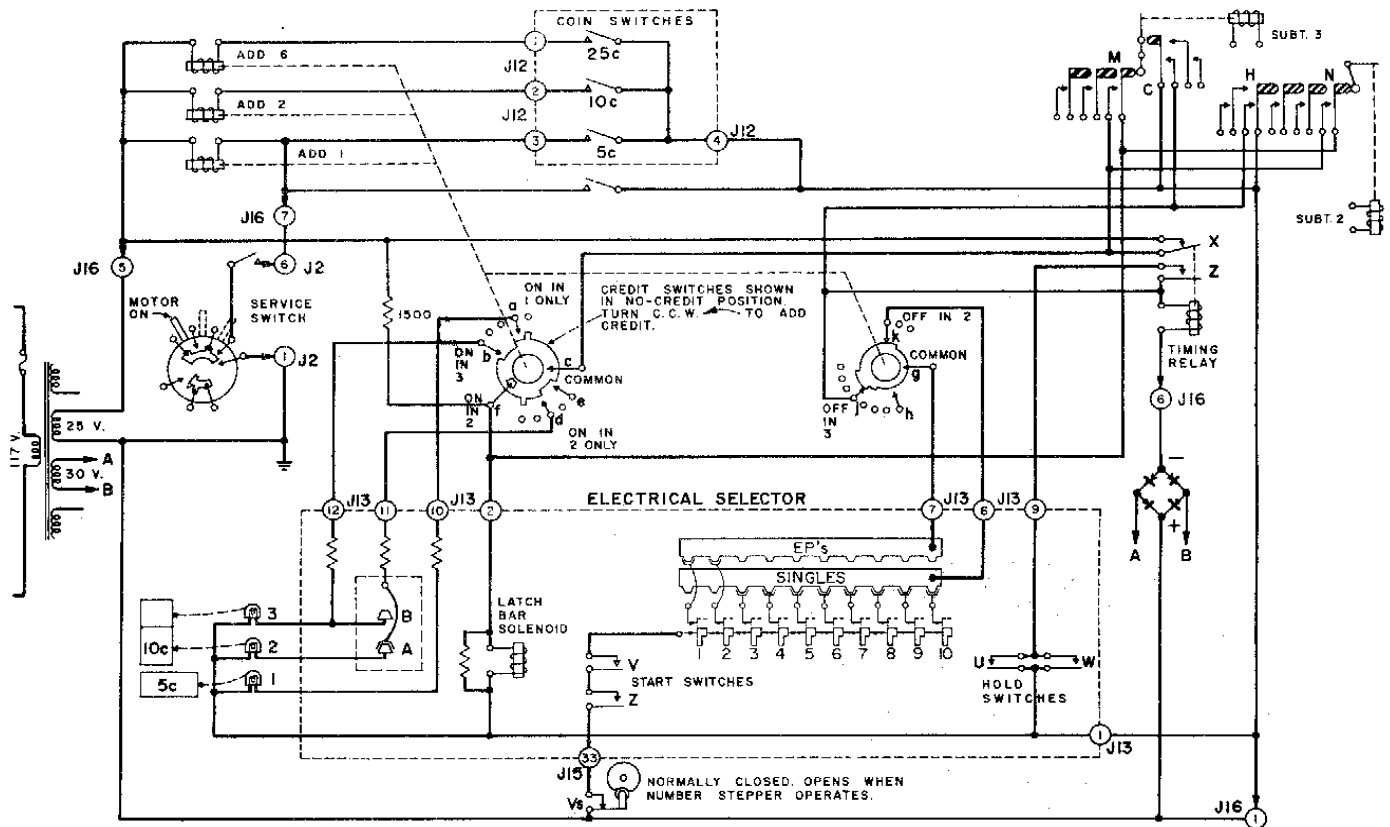

Figure 3.

**OPERATION**

Figures 3 and 5 diagram the Dual Credit Unit and the Tormat Electrical Selector circuits involved in its operation. Figure 3 shows the circuits associated with credits. Figure 5 shows the subtract (select) circuits. The pricing terminal board in the diagrams is arranged so program selections A1 to V1 and A2 to V2 are "sold" for 15 cents (3 credit units) each. All other selections will be played for 10 cents (2 credit units) each. The credit switch is in the no-credit position.

Referring to Figure 3: Momentary operation of the nickel credit solenoid by closing the nickel coin switch or by a single operation of either manual credit switch will move the credit switch one credit unit and close a circuit to the "5-cent" light through credit switch contacts a and c and contact X of the timing relay. No other circuit conditions are changed. If, in this credit condition, selection is attempted, the timing relay will be energized through k and j (or g and j) of the back section of the credit switch, the number selector switch that is pressed, the start switches (contacts V and Z) and contact Vs in the step switch assembly. The

circuit to the credit indicating light will open at contact X. The relay will be energized until both selector keys are released. The timing relay circuit is shown simplified in Figure 4.

If a second nickel is now deposited or a manual credit switch operated again, a second credit unit will be added and the credit switch will be two positions or credit units from the no-credit position. Contact a will now be open so the "5-cent" light is turned off and the "10-cent" light will turn on through d and c of the front credit switch section. The latch bar solenoid in the Electrical Selector will be energized through f and c of the credit switch and X of the timing relay.

If, in this credit condition, a selection is attempted that includes the number 1 or 2 selector key, the timing relay will be energized through g and j of the credit switch, the pressed-in selector switch, the start switches and contact V in the step switch assembly. The circuit to the credit light and the latch bar solenoid will open at relay contact X. The latch bar will release the selector switches

TORMAT SELECTION RECEIVER, TYPE TSRI-L6

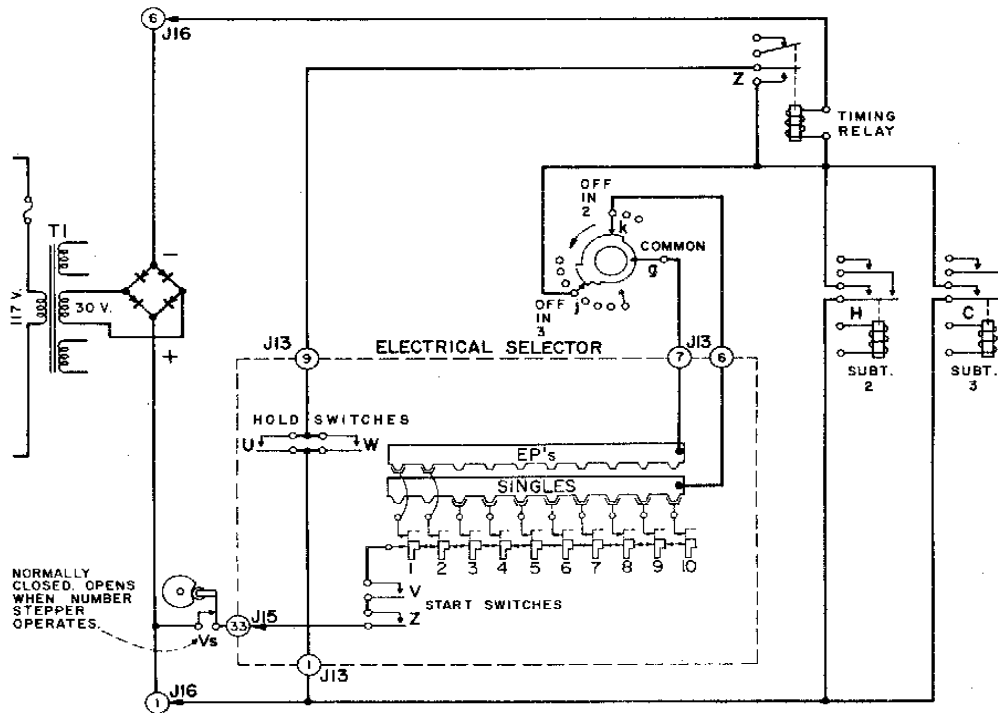

Figure 4.

and open the relay circuit. If either the letter or number selector key is held in, the relay circuit will be maintained through a Hold Switch (contacts U and W) in the Selector and timing relay contact Z. The condition and circuit can be traced in Figures 3 or 5.

If a third nickel is deposited, or if either manual credit switch is operated for the third time, the credit switch will advance to the 3-credit-unit position, the latch bar solenoid will remain energized, the "10-cent" light will be turned off and the "15-cent" light will turn on to indicate that ANY selection may be played.

Referring to Figure 5: If, in the 2-credit-unit position of the credit switch, a selection is made that includes any numbered selector switch other than number 1 or 2, the subtract-2 solenoid will be energized and the credit switch will be rotated clockwise to the no-credit position. The circuit is through contact X of the timing relay, c and e of the front section of the credit switch, the solenoid, terminal 6 of the Electrical Selector plug, the "SINGLES" strip of the pricing terminal board, the number selector switch, the start switches and contact Vs in the Step Switch Assembly.

When the solenoid plunger pulls in, contact F shunts e and c of the credit switch so the solenoid circuit is not opened by rotation of the

switch to the no-credit position. Contact G connects the solenoid to ground by "shorting out" the selection switch, start switches, and contact Vs. A full stroke of the plunger is assured. The circuit is more readily visualized in the simplified diagram. Figure 6.

Contacts H, I, J, L and N are also closed by this solenoid operation. The scan solenoid is energized through contact I (if the service switch is in the normal "motor on" position). The "SINGLES" selection counter is energized through contact J. Contact L grounds the grid of the write-in 2D21 thyratron so the selected core in the Tormat Memory Unit will be conditioned for selection. The timing relay will be energized through contact H and will open the subtract solenoid circuit at contact X so the solenoid plunger is released to its normal rest position.

Contact N is a carry-over contact for the latch bar solenoid. It shunts contact f (and c) of the credit switch so power to the solenoid will not be interrupted at f as the credit switch is rotated (by the subtract solenoid) from the 2-credit position. The circuit to the latch bar solenoid is opened at contact X when the timing relay is energized. Opening the solenoid circuit releases the selector switches (and keys) so they return to their normal position. If either, or both, selector keys are held in, the timing relay will continue to be energized

TORMAT SELECTION RECEIVER, TYPE TSRI-L6

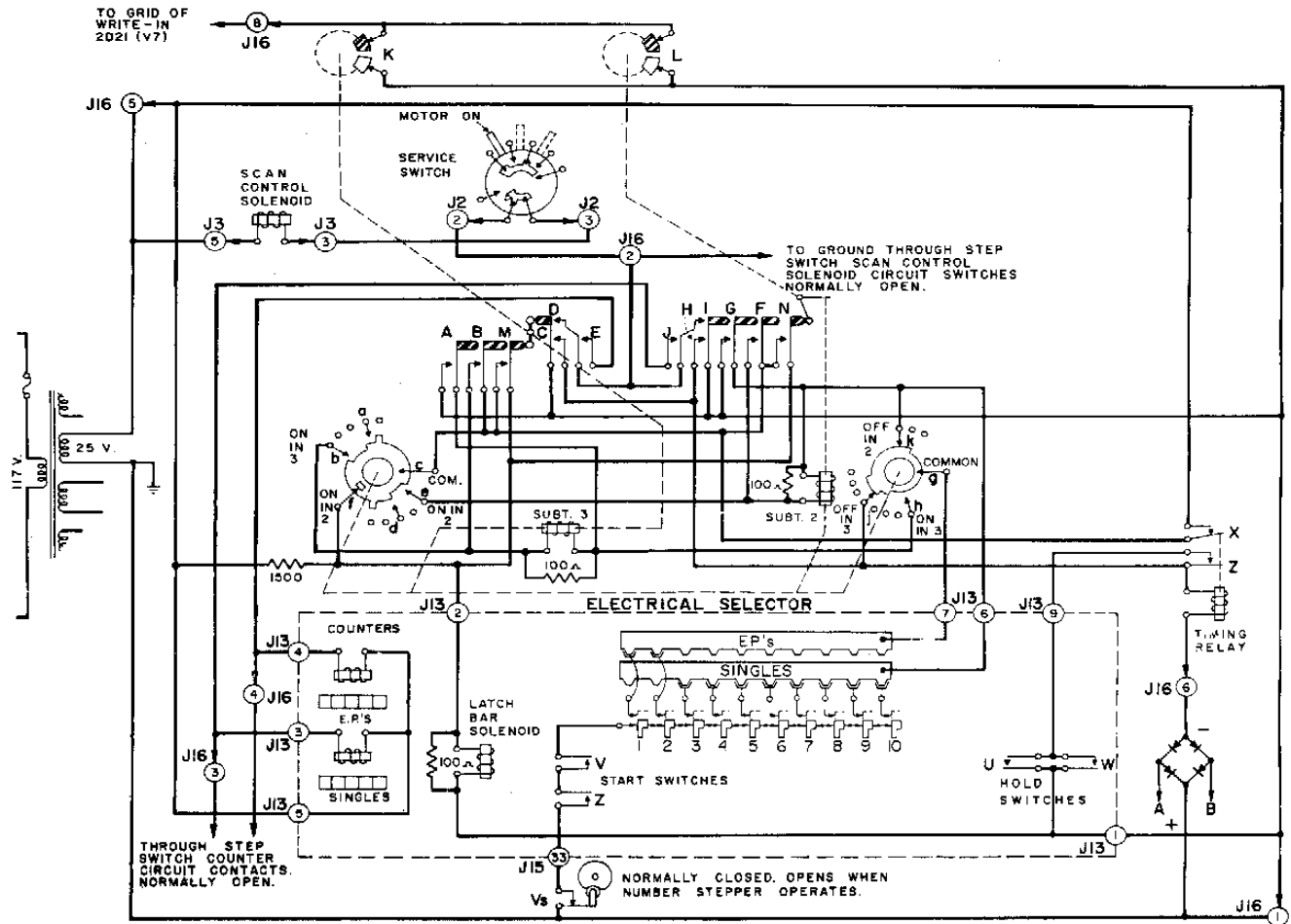

Figure 5.

through the Hold Switches in the electrical selector and contact Z of the relay.

If, when the subtract-2 selection sequence is started, the credit switch is in a position of four or more credit units, the latch bar solenoid circuit still will be complete through the credit switch and contact N is not utilized. N serves only to prevent arcing at f due to interruption of the latch bar solenoid current.

The 1500 ohm resistor shown adjacent to contact X of the timing relay in Figure 3 passes a charging current of low value through the latch bar solenoid so residual magnetism will not hold the solenoid plunger in the energized position when the full-current circuit to the solenoid is opened at contact X.

If, when the subtract-2 selection sequence is started, the credit switch is in a position corresponding to four or more credit units, the latch bar solenoid circuit will still be complete through the credit switch but will be open at the X contact of the timing relay as long as the relay is energized. Opening the solenoid circuit releases the selector switches (and

keys) so they return to their normal position. If either, or both, selector keys are held in, the timing relay will continue to be energized through the Hold switches in the Selector and contact Z of the relay.

A total of three or more credit units will position the credit switch so a 3-credit-unit selection can be made. Referring to Figure 5: The subtract-3 solenoid will be energized if a selection is made that makes use of either the number 1 or 2 selection switch. The circuit is through contact X of the timing relay, c and b of the front section of the credit switch, the solenoid, h and g of the back section, terminal 7 of the Electrical Selector plug, the "EP" strip of the pricing terminal board, the number 1 or 2 selector switch, the start switches and contact Vs. The operation involving this solenoid is equivalent to that of the subtract-2 solenoid except that three credit units are subtracted from any existing credit unit total and the "EP" counter will be operated. In the subtract-3 switch group, the carry-over contact B shunts the c and b terminals of the front section of the credit switch to maintain a circuit if the selection is

## TORMAT SELECTION RECEIVER, TYPE TSRI-L6

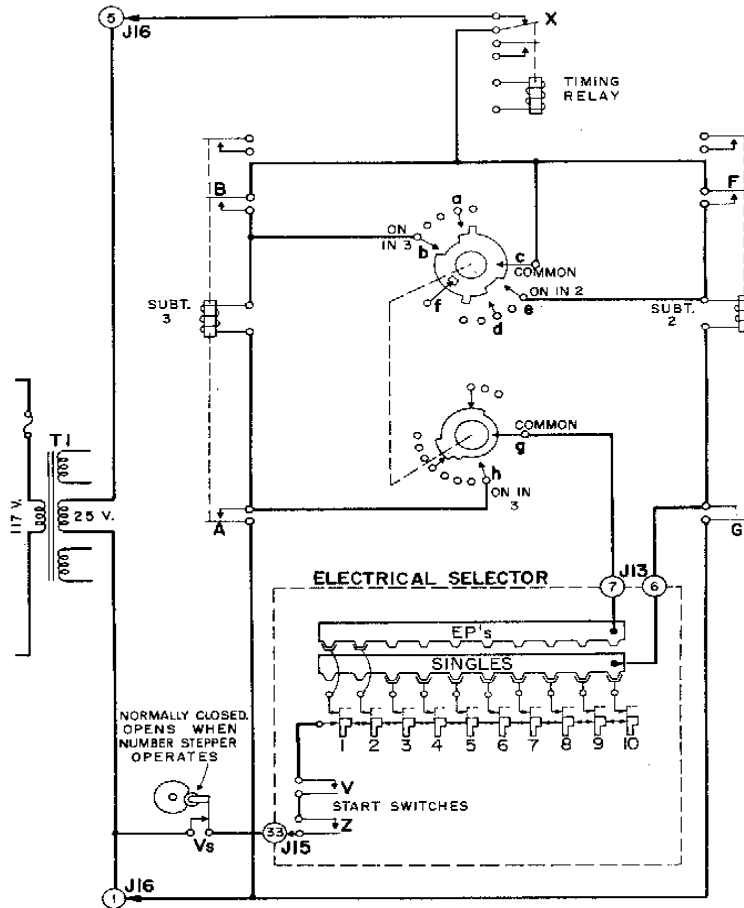

Figure 6.

started with less than six credit units available. Contact A, by connecting the solenoid to ground, serves the same purpose by shunting the back section of the credit switch as well as the selection switch, start switches and contact Vs.

Contact Vs, normally closed and open only when the number stepper of the step switch assembly is operating, disables the Electrical

Selector and prevents cross-connecting selection circuits of the Tormat Memory Unit by operating Selector keys while selection is made from a remote control Wall-O-Matic.

The 100 ohm resistors connected across the latch bar and the subtract solenoid coils minimize contact arcing.

### STEP SWITCH AND RELAY ASSEMBLY OPERATION

The Step Switch and Relay Assembly is a part of the Seeburg Tormat Memory System. Its functions are to connect a Letter and a Number Circuit of the Tormat Memory Unit into a selection write-in circuit and initiate mechanism operation in accordance with selection made with a Type V-3WA Wall-O-Matic. The assembly consists of two step switches, a reset magnet, a transfer relay, two timing relays, a selection pricing terminal board, and a play control relay. (The play control relay is not directly involved in the operation of the remote control system.)

When a selection is made from a Wall-O-Matic, a rotating switch blade in the Wall-O-Matic causes intermittent grounding of the grid of a 2D21 tube in the selection receiver. The

grounding occurs in two series of "pulses". These pulses are of approximately 1/25 second duration with a 1/25 second interval between each successive pulse and with approximately 1/5 second interval between the two series. The number of pulses in each of the two series is determined by which selector buttons are operated at the Wall-O-Matic and will determine, in turn, which write-in circuits in the Tormat Memory Unit will be energized.

Each time the grid of the 2D21 tube is grounded during one of the pulses, the tube passes current through its plate circuit and a step relay coil in that circuit. The relay coil attracts its armature and operates the ratchet of the step switch so the switch is advanced one step. In the normal rest position of the Assembly,

## TORMAT SELECTION RECEIVER, TYPE TSRI-L6

none of the relays are energized, the two step switches are in "zero" position and the coil of the Letter Step Relay is in the plate circuit of the tube through contact A of the transfer switch. When a selection is made, the first pulse of the first series energizes the Letter Step Relay, advances the step switch one contact, and closes contacts G and F. Contact G completes a d.c. circuit to the reset magnet to be energized and engage pawls with the ratchets of both step relays, Contact F completes a d.c. circuit to the transfer relay so it is energized opening contact D and closing contact E. Both the reset magnet and the transfer relay have slow-release timing so they will remain in the energized positions for an appreciable time after the first pulse has ended to permit the step relay armature to return to its normal position with contacts G and F open. Before either relay will drop out, the second pulse of the series operates the armature of the step relay and again the relays are energized. As long as the pulses continue with 1/25 second intervals between them the following condition will prevail: contacts G and F open and close with each pulse from the Wall-O-Matic, the pawls engage with the step switch ratchets, and the transfer relay contact E remains closed. Because the ratchets are engaged by the pawls, the step relay will advance the step switch one step or contact with each pulse.

When the second pulse of the first pulse series advances the step switch a second time, a cam on that switch operates the make-before-break contacts of the transfer switch so the 2D21 tube plate circuit is connected to the Letter Step Relay through contact B of the transfer switch (A is now open) and contact E of the transfer relay. This circuit condition is retained through subsequent steps of the Letter Step Switch.

The 1/5 second interval between the end of the last pulse of the first series and the beginning of the first pulse of the second series causes the Letter Step Relay to open the G and F contacts long enough to allow the transfer relay to drop out but not long enough to allow the reset magnet to disengage the step switch ratchet pawls. Therefore, during this 1/5 second interval when the transfer relay drops out, the step switch remains in the advanced position and the plate circuit of the 2D21 tube is transferred to the Number Step Relay through contact D of the transfer relay. When the first pulse of the second series operates the tube, the Number Step Relay will be energized and contacts J and H will be closed for the duration of the pulse.

Contact H energizes the reset magnet so it maintains its energized position as long as the pulses of the second series operate the Number Step Relay, Contact J closes the d.c. circuit to the No. 1 timing relay. This relay has slow-release timing so it remains in the energized position during the 1/25 second intervals between the pulses forming the second series. When the relay is energized contacts S and T open and contact U closes. Contact U closes the d.c. circuit to the No. 2 timing relay which, in turn, closes contacts M, L, P, and Q and opens contacts N and R.

The conditions prevailing as long as the pulses of the second series continues with 1/25 second interval between them are: advance of the Number Step Switch with each pulse; the reset magnet energized so the Letter Step Switch is in its advance position; the timing relays No. 1 and No. 2 energized.

With the first step of the Number Step Switch, the normally closed contact V is opened by a cam on the switch. This contact, when open, disables the starting circuit of the Electrical Selector system so no selection can be made during the interval the Number Step Relay is being operated by Wall-O-Matic selection.

Contacts P and R of the No. 2 timing relay disable the common return circuits of the Letter and Number Circuits of the Tormat Memory Unit so these circuits cannot be connected to the step switches by operation of the Electrical Selector selection keys while the timing relay is energized (during selection from a Wall-O-Matic). The normally open contact K on the pawl release relay closes at the first step operation of the Letter Step Relay to connect the Step Switch Assembly in the read-in circuit of the Memory Unit.

After the last pulse of the second series has operated the Number Step Relay, contacts J and H remain open and the No. 1 timing relay drops out. When this occurs, contact U opens and S and T close.

When contact U opens, the No. 2 timing relay coil is no longer energized but due to slow-release timing, the relay remains in the energized condition for an interval of approximately 1/20 second. During this interval, the grid of the 2D21 write-in thyratron is grounded through contacts S and P; the write-in circuit to the Tormat Memory Unit is closed through contacts Q and K; the selection counter circuit is completed to ground through the Number Step Switch and contacts M and T; the scan control

# TORMAT SELECTION RECEIVER, TYPE TSR1-L6

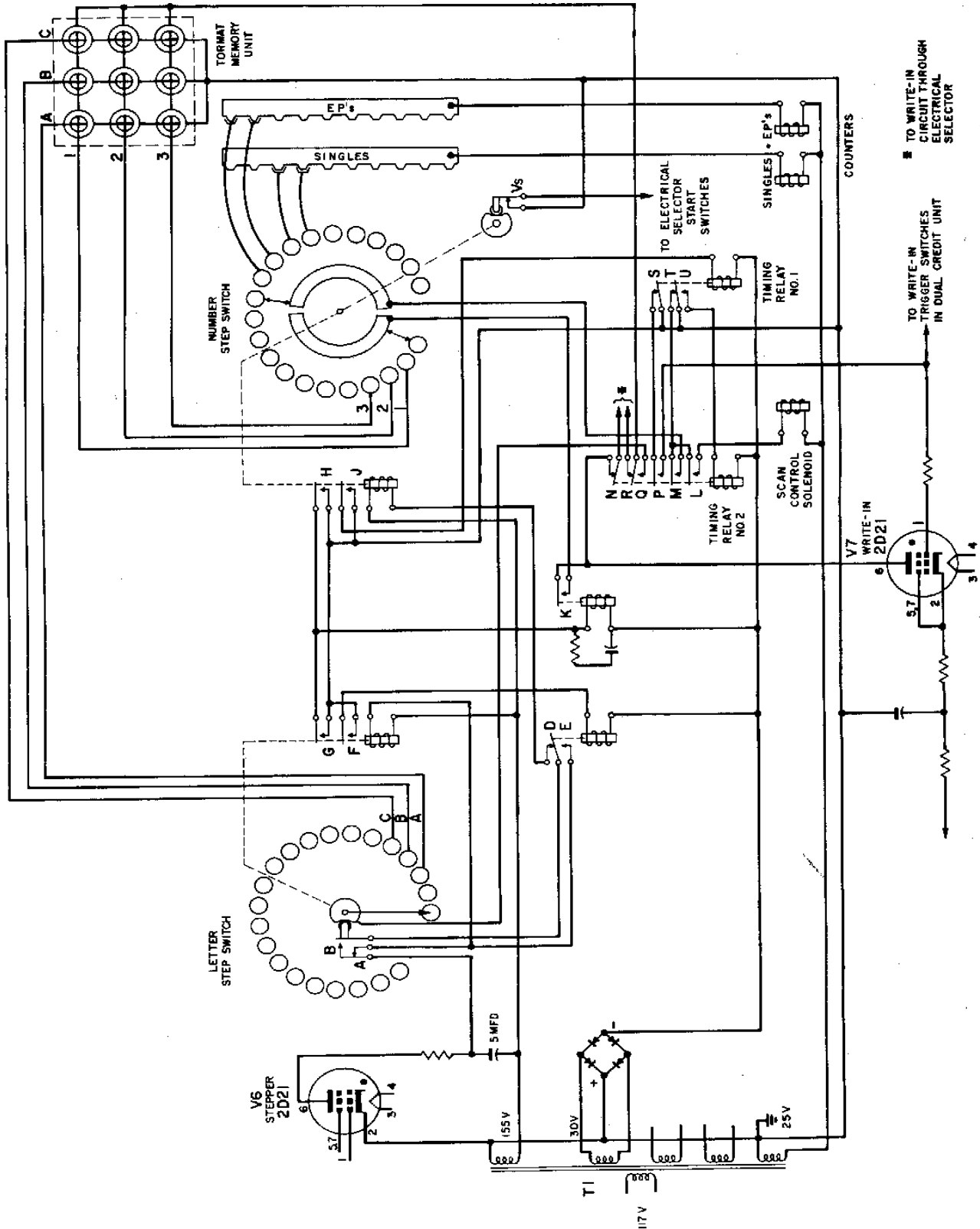

Figure 7.

## TORMAT SELECTION RECEIVER, TYPE TSRI-L6

solenoid circuit is completed to ground through contacts L and T. During this interval, then, the 2D21 write-in thyatron is "fired" to energize the write-in circuits of the Memory Unit, that are connected through the step switches; the "Singles" or "EP" selection counter is operated (as determined by the connections pre-set at the pricing terminal board and the Number Circuit selected); the scan control solenoid will be energized so the scan switch is reset for continued operation of the mechanism and phonograph amplifier.

When the No. 2 timing relay releases, these circuits are opened and cleared and the write-in circuits are again conditioned for selection with the Electrical Selector.

The release delay for the pawl reset magnet extends slightly longer than the total time interval required for drop-out of the No. 2 timing relay so the step relay ratchets are released after the timing relay has opened the circuits it controls. When the step switch ratchets are released, the switches return to the "zero" position. Return of the Number Step Switch permits contact Vs to close so the Electrical Selector is no longer disabled.

The selection pricing terminal board associated with the Step Switch Assembly provides means for simple connection of the selection counters (in the Electrical Selector) so they will total in accordance with the selection pricing established for the Wall-O-Matics and the Electrical Selector. There is a flexible lead for each of the ten Number Circuits. This lead is connected to either the "EP" terminal strip or the "Singles" terminal strip on the pricing board. If the leads associated with Number Circuit No. 1 and Number Circuit No. 2 are connected to the "EP" terminal strip, all selections in which the No. 1 and No. 2 appear

will register in the total shown by the "EP" counter.

The number of steps the Letter Step Switch makes during the first series of pulses determines which one of twenty Letter Circuits of the Tormat Memory Unit will be energized. The number of steps made by the Number Step Switch will determine which one of ten Number Circuits of the Memory Unit will be energized. The selection made, then, will require from two to twenty-one pulses in the first series and from one to ten in the second series with the predetermined interval of approximately 1/5 second between the two series.

It is to be noted that operation of the relays is determined largely by the time interval between pulses, not by the duration of the individual pulses. The individual pulses of a selection series must be of only sufficient duration to insure full operating strokes of the step relay armatures but may be of any duration more than this minimum requirement. The intervals between the pulses must be long enough for the step relay armatures to return to normal position for another stroke but not long enough to permit the transfer relay to release during the first series or the No. 1 timing relay to release during the second series. The interval between the last pulse of the first series and the first pulse of the second series must be timed to permit the transfer relay to release but must not be long enough to allow the release magnet to return to normal position.

Both the pulse length and the intervals between pulses is determined by the design and operation of the Wall-O-Matic. The contacts on the selector plate and the rotating control arm of the Wall-O-Matic are arranged for correct pulsing when the arm operates between the speed limits of 17 to 21 revolutions per minute.

TORMAT SELECTION RECEIVER, TYPE TSR1-L6

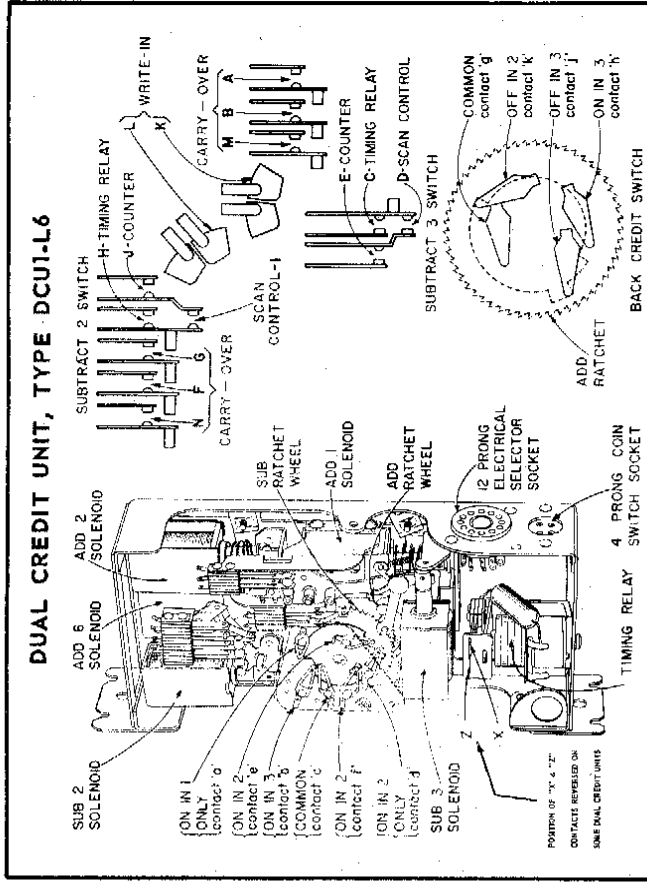
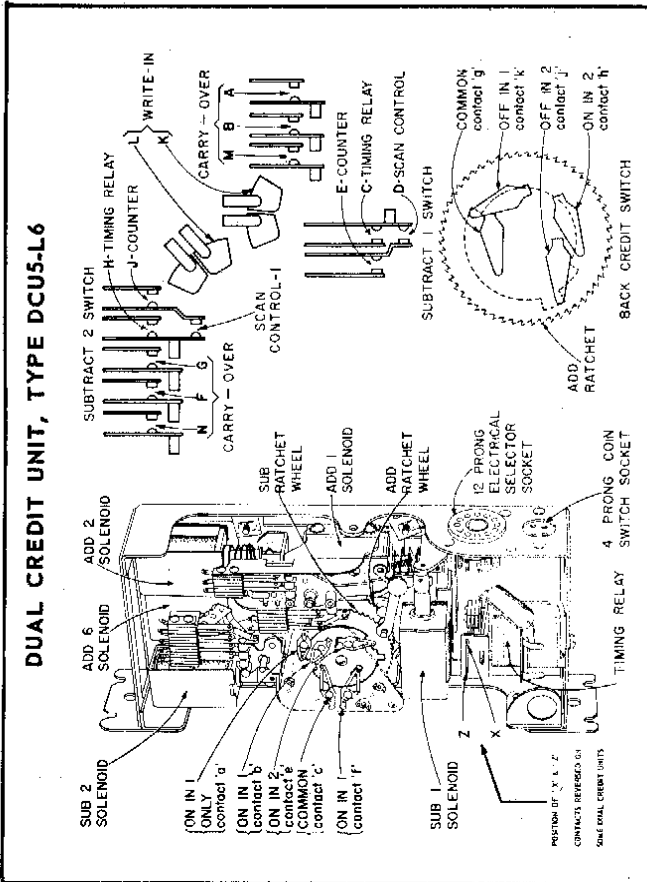

CONTACT	PRESSURE WHEN CLOSED	CONTACT GAP	NORMAL POSITION
A	1 OZ. MIN.	.010 - .015	OPEN
B	1 OZ. MIN.	.010 - .015	OPEN
C	7/8 OZ. MIN.	.004 - .007	OPEN
D	7/8 OZ. MIN.	.025 - .035	OPEN
E	2/3 OZ. MIN.	.008 - .012	OPEN
F	1 OZ. MIN.	.010 - .015	OPEN
G	1 OZ. MIN.	.010 - .015	OPEN
H	1 OZ. MIN.	.008 - .012	OPEN
I	1 OZ. MIN.	.025 - .035	OPEN
J	2/3 OZ. MIN.	.010 - .015	OPEN
K	7/8 OZ. MIN. AGAINST PLATE	NONE	OPEN
L	7/8 OZ. MIN. AGAINST PLATE	NONE	OPEN
M	2/3 OZ.	.028	OPEN
N	2/3 OZ.	.008	OPEN
X	1-1/2 OZ.	1/32"	CLOSED
Z	1-1/2 OZ.	1/32"	OPEN

\* Contacts C and H must be closed when respective pawl arm drive pin bottoms in credit wheel tooth.

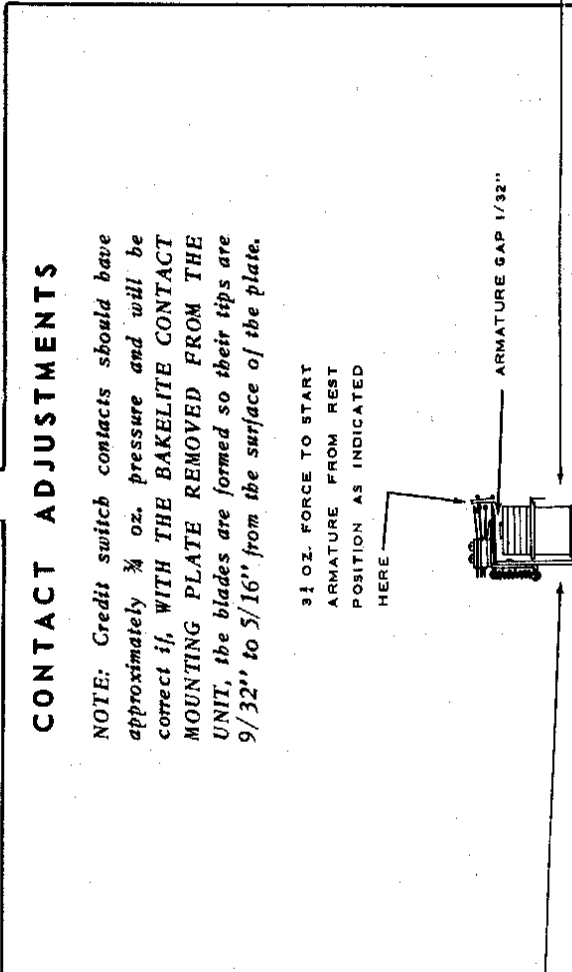

CONTACT	PRESSURE WHEN CLOSED	CONTACT GAP	NORMAL POSITION
A	1 OZ. MIN.	.010 - .015	OPEN
B	1 OZ. MIN.	.010 - .015	OPEN
C	7/8 OZ. MIN.	.004 - .007	OPEN
D	7/8 OZ. MIN.	.025 - .035	OPEN
E	2/3 OZ. MIN.	.008 - .012	OPEN
F	1 OZ. MIN.	.010 - .015	OPEN
G	1 OZ. MIN.	.010 - .015	OPEN
H	1 OZ. MIN.	.008 - .012	OPEN
I	1 OZ. MIN.	.025 - .035	OPEN
J	2/3 OZ. MIN.	.010 - .015	OPEN
K	7/8 OZ. MIN. AGAINST PLATE	NONE	OPEN
L	7/8 OZ. MIN. AGAINST PLATE	NONE	OPEN
M	2/3 OZ.	.008	OPEN
N	2/3 OZ.	.008	OPEN
X	1-1/2 OZ.	1/32"	CLOSED
Z	1-1/2 OZ.	1/32"	OPEN

\* Contacts C and H must be closed when respective pawl arm drive pin bottoms in credit wheel tooth.

**ADD 6 (25¢) DRIVE ADJUSTMENT**

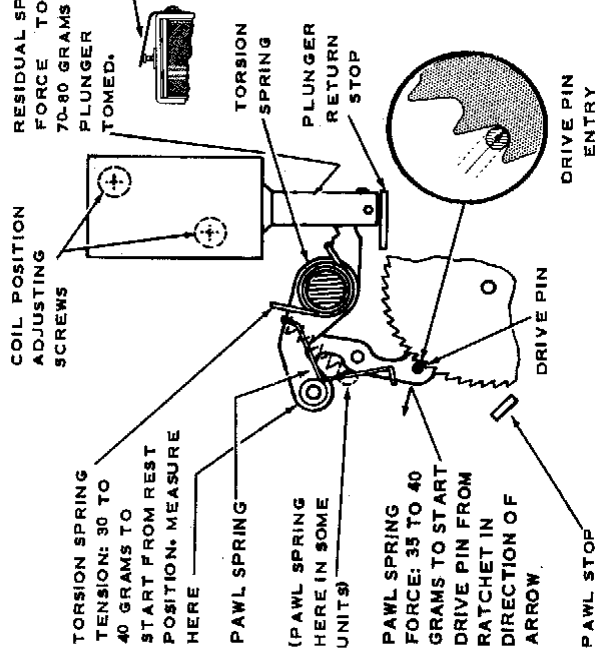

- A. With wheel stop against stop pin, adjust stop pin position so ADD 6 drive pin enters ratchet without striking or rubbing the sides of the teeth.
- B. Loosen the two screws holding the coil.
- C. Operate the plunger manually by applying force at the end of the plunger (*not the levers*) so it is fully seated.
- D. Position the coil so the plunger operation will move the wheel six teeth and be fully detented. Tighten screws holding the coil.
- E. Adjust pawl stop for minimum play in wheel when plunger is fully seated.
- F. Adjust plunger return stop position for clearance between the drive pin and the tips of the ratchet teeth. The tips should pass without rubbing but the clearance must not be more than .010".

**ADD 2 (10¢) DRIVE ADJUSTMENT**

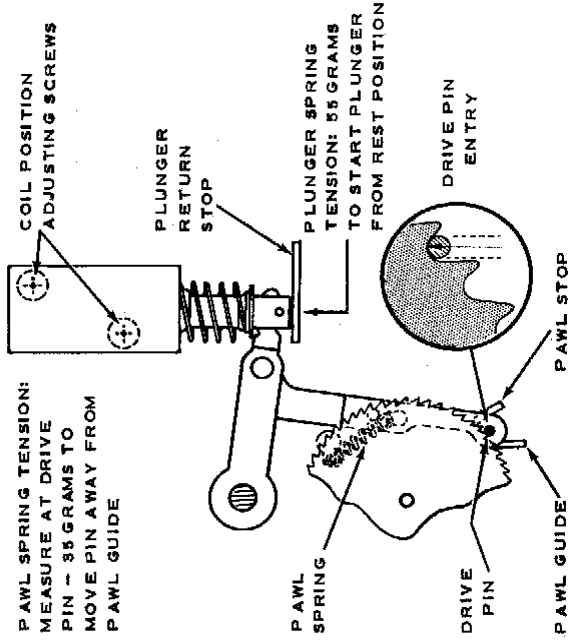

- A. Adjust pawl guide so drive pin enters ratchet without striking or rubbing the sides of the teeth.
- B. Loosen the two screws holding the coil.
- C. Operate the plunger manually by applying force at the end of the plunger (*not the levers*) so it is fully seated.
- D. Position the coil so the plunger operation will move the wheel two teeth and be fully detented. Tighten screws holding the coil.
- E. Adjust pawl stop for minimum play in wheel when plunger is fully seated.
- F. Adjust plunger return stop position for clearance between the drive pin and the tips of the ratchet teeth. The tips should pass without rubbing but the clearance must not be more than .010".

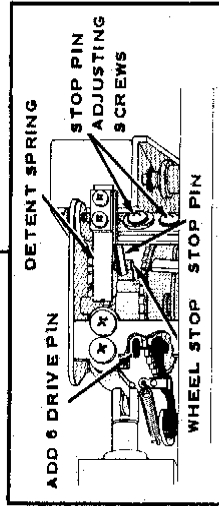

**WHEEL STOP AND DETENT ADJUSTMENT**

- A. With wheel stop against stop pin, adjust stop pin position so ADD 6 drive pin enters ratchet without striking or rubbing the sides of the teeth.  
*Entry of all drive pins and the detent spring position adjustments are effected by the stop pin position and should be checked if a change is made.*
- B. Adjust position and force of detent spring so roller is *in full detent* when wheel stop is against stop pin and roller pressure against wheel is 150 to 160 grams (5½ oz.).

TORMAT SELECTION RECEIVER, TYPE TSRI-L6

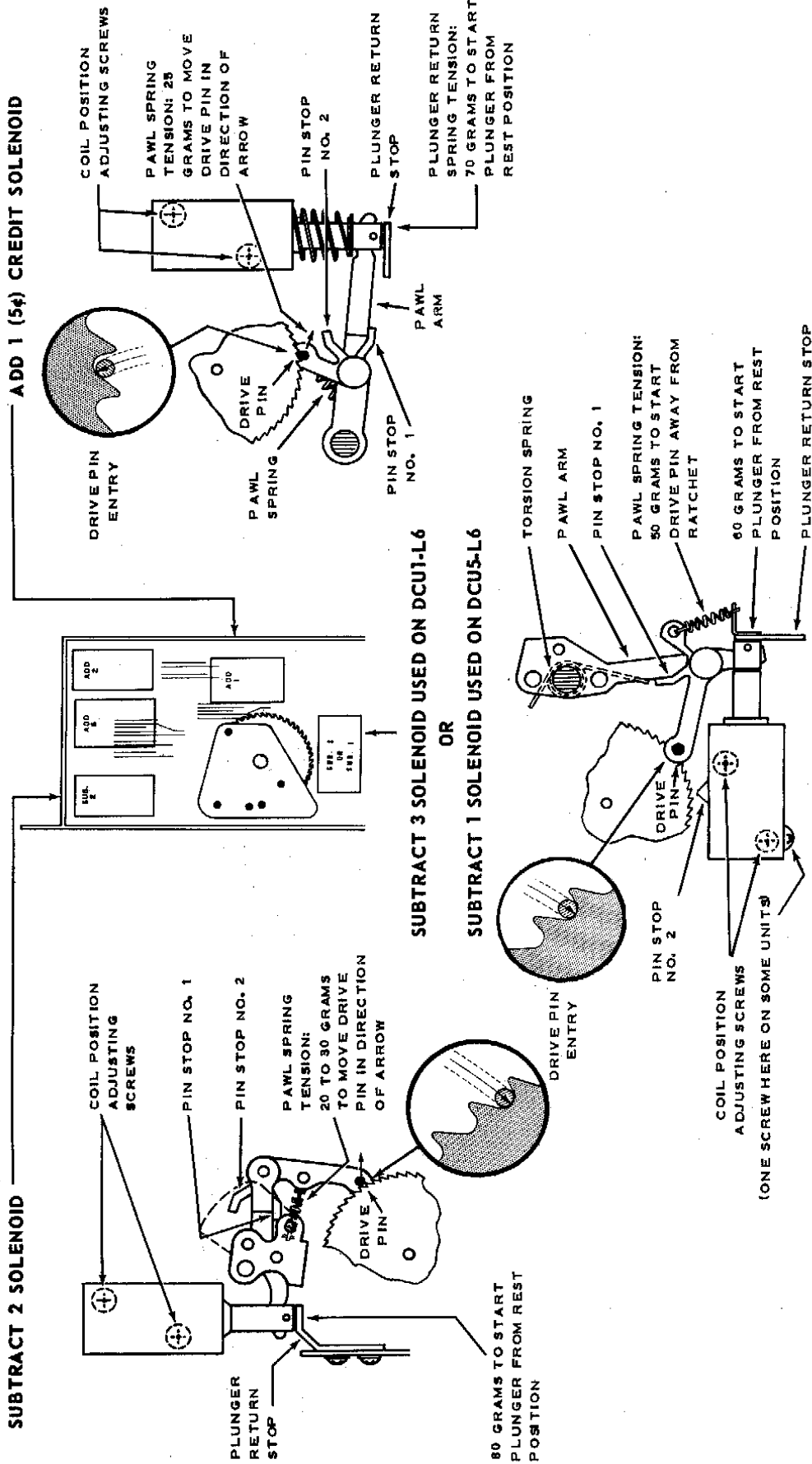

- A. Adjust pin stop No. 1 so the drive pin enters the ratchet without striking or rubbing the sides of the teeth.
- B. Adjust the plunger return stop position for clearance between the drive pin and the tips of the ratchet teeth. The tips should pass without rubbing but the clearance must not be more than .010".
- C. Loosen the two screws holding the coil.
- D. Operate the plunger manually by applying force at the end of the plunger (*not the levers*) so it is fully seated.
- E. Position the coil so the plunger operation will move the wheel the required number of teeth and will be in full detent. Tighten screws holding the coil.
- F. Adjust pin stop No. 2 for minimum play in wheel when plunger is fully seated.

TORMAT SELECTION RECEIVER, TYPE TSR1-L6

ITEM	OPERATED BY	ARMATURE GAP INCHES	CONTACTS	CONTACT		
				GAP INCHES	PRESSURE OUNCES	NORMAL POSITION
TIMING RELAY NO. 1*	CONTACT "J"	1/32	S T U	1/64 1/64 1/64	1 3/4 1	CLOSED CLOSED OPEN
TIMING RELAY NO. 2*	CONTACT "U"	3/64	L M N P Q R	1/64 1/64 1/64 1/32 1/64 1/64	1 3/4 1 1 3/4	OPEN OPEN CLOSED OPEN OPEN CLOSED
COUNTER TERMINAL BOARD	EACH TAPER TAB RECEPTACLE CORRESPONDING TO EACH NUMBER IS TO BE PLACED ON THE DESIRED TERMINAL STRIP, EP'S OR SINGLES. BE CERTAIN THAT THE TERMINAL BOARD ON THE TORMAT ELECTRICAL SELECTOR AND EACH TERMINAL BOARD IN ALL THE WALL BOXES ARE CONNECTED IN THE SAME MANNER.					
START SWITCH	CAM ON NUMBER STEP SWITCH		V	1/64	1 1/4	CLOSED
NUMBER STEP MAGNET	CONTACTS "D" AND "B" AND TUBE V6		H J	1/64 1/64	1 1	OPEN OPEN
RESET MAGNET †	CONTACT "G" OR "H"		K	1/64	1 1/4	OPEN
TRANSFER SWITCH	CAM ON LETTER STEP SWITCH		A B	1/64 1/64	1 1	CLOSED OPEN
LETTER STEP MAGNET †	CONTACTS "A" OR "B" AND "E" AND TUBE V6		F G	1/64 1/64	1 1	OPEN OPEN
TRANSFER RELAY*	CONTACT "F"	3/64	D E	1/32 1/32	1 1	CLOSED OPEN
PLAY CONTROL RELAY †	SCAN CONTROL SWITCH (CONTACT "D") ON SCAN CONTROL ASSEMBLY	3/64	C	1/32	1 1/2	OPEN

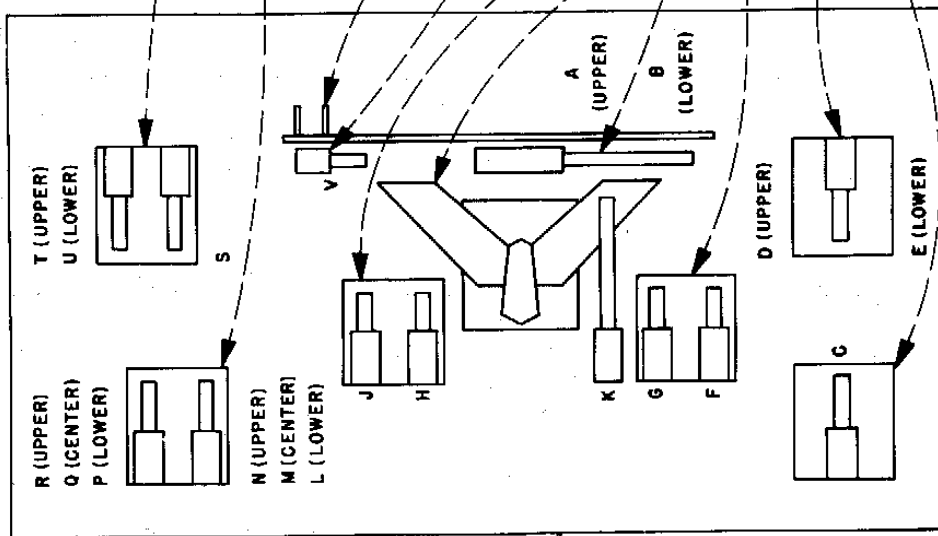

**TAIL SPRING FORCES**  
 TIMING RELAY NO 1 4 OZ.  
 TIMING RELAY NO 2 2-1/3 OZ  
 PLAY CONTROL RELAY 1-2/3 OZ  
 TRANSFER RELAY 1-2/3 OZ

**D. C. COIL RESISTANCE**  
 \* - 500 OHMS  
 □ - 800 OHMS  
 † - 325 OHMS  
 △ - 40 OHMS

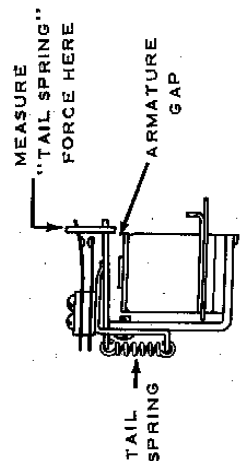

Figure 9. Relay Adjustment

## STEP SWITCH ASSEMBLY ADJUSTMENTS

### RATCHET AND SWITCH

The ratchets are attached to the switch shafts with pins or set screws. They should be positioned so the outer blades of the switches are approximately centered on the lowest contact (on the contact plate) when the stud on the side of the ratchet wheel is against the stop on the assembly frame.

The ratchets should be set on the shafts for a minimum of end play consistent with no binding.

### RATCHET RETURN SPRING

The return spring tension for the Letter step switch should require 90 to 115 grams ( $3\frac{1}{4}$  to 4 oz.) tangential force to move the ratchet to the 5th position of the step switch. This force is measured at the point of a ratchet tooth with the switch contact plates removed. It will be approximately correct if the spring is wound one full turn when the switch is in the rest position.

The return spring tension for the Number step switch should require 60 to 75 grams ( $2$  to  $2\frac{3}{4}$  oz.) tangential force to move the ratchet to the 5th position. The tension will be approximately correct if the spring is wound  $\frac{3}{4}$ -turn when the switch is in the rest position.

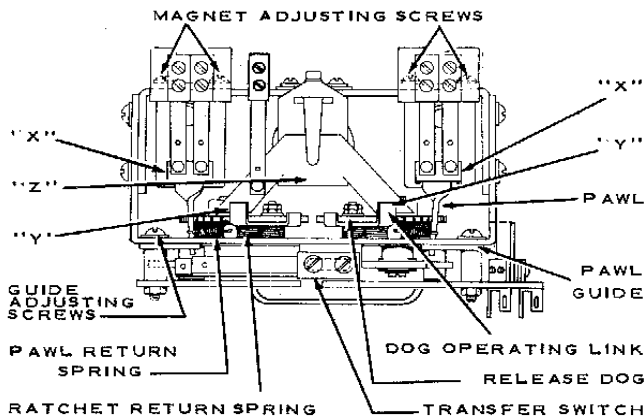

Figure 10.

### STEP RELAY MAGNET POSITION

Adjust the step relay magnet vertically so the ratchet wheel tooth will over-ride the end of the release dog  $.010''$  to  $.020''$  when the armature is seated. *Figure 11.*



Figure 11.

With the pawl against the upper edge of the pawl guide opening, the clearance between the ratchet teeth and the pawl should not be less than  $.005''$ .

### PAWL GUIDE AND RETURN SPRING

Adjust the pawl guides so the pawls will strike the bottom of the ratchet teeth when the pawl engages the ratchet. *Figure 12.* The adjustment must be made so there will be a  $.004''$  to  $.010''$  gap between the pawl and the guide at the bottom of the stroke. *Figure 13.*

The pawl return spring tension should require 10 to 15 grams ( $\frac{1}{2}$  oz.) force to start the pawl from the side of the guide. Measure this force at the spring with the pawl in the rest position.

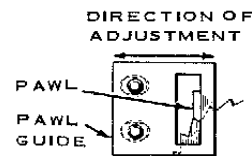

Figure 12.

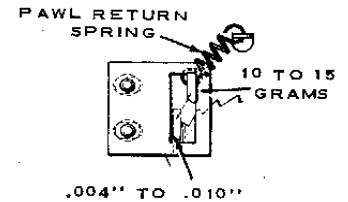

Figure 13.

### STEP MAGNET TAIL SPRINGS

The tail spring pressure, measured at the front of the bridge on the step magnet armature ("X", *Figure 10*) should be 50 to 75 grams ( $1\frac{3}{4}$  to  $2\frac{1}{2}$  oz.) to just close the switch contacts (when the contacts are correctly adjusted).

### CONTACT PLATE SWITCH BLADES

The switch blades should have 10 to 35 grams pressure against the contacts. The pressure will be approximately correct if the blades are formed so their tips extend  $\frac{5}{32}''$  above the contact assembly when the plates are removed. *Figure 14.*

When the contact plates are in position the blades should move freely over the contacts. If the contacts become rough or gummed, they should be cleaned with a clean cloth moistened, slightly, with light oil. *Do not use sandpaper or emery cloth and do not lubricate them with vaseline, grease or oil.*

### RESET MAGNET POSITION

Adjust the reset magnet vertically so the release dogs engage the ratchet teeth with the armature extension clearing the dimples ("Y", *Figure 10*) on the dog operating links  $\frac{1}{64}''$  when the magnet is energized. *Figure 14.*

## TORMAT SELECTION RECEIVER, TYPE TSRI-L6

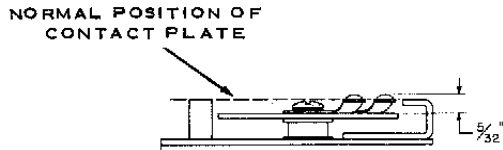

Figure 14.

The armature travel must be sufficient to permit the release dogs to clear the ratchet teeth .010" minimum when the magnet is not energized.

The tabs on the release dog operating links which engage the dogs and couple them to the reset magnet should not bind tightly but should not permit more than .005" free travel between the dogs and the links.

### RESET MAGNET TAIL SPRING

The pressure applied to the end of the reset magnet armature ("Z", Figure 10) to start it from the rest position should be 100 to 140 grams (3-1/2 to 5 oz.).

### RELEASE DOG SPRINGS

An upward pressure of 15 to 20 grams (1/2 to 3/4 oz.) applied at the dimple on the release dog operating links ("Y", Figure 10) should start the dogs from seated position. This pressure will be approximately correct if the springs are wound 1/2 to 3/4 turn.

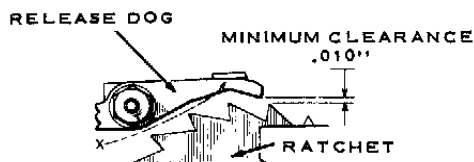

Figure 15.

### TRANSFER SWITCH POSITION AND ADJUSTMENT

Adjust the position of the switch on the mounting bracket so the roller is in the notch of the contactor assembly disc and the first operation of the step magnet causes no change of the roller blade. The second operation of the step

magnet should raise the roller to the outer diameter of the disc. The flanges of the roller should not drag on the disc and the roller bracket should not strike the switch contact plate.

- (a) With the step switch in the rest position so the roller is in the notch of the contactor disc, adjust the lower blade for 1/2 to 3/4 oz. pressure of the roller against the disc.
- (b) Adjust contact "B" gap 1/64".

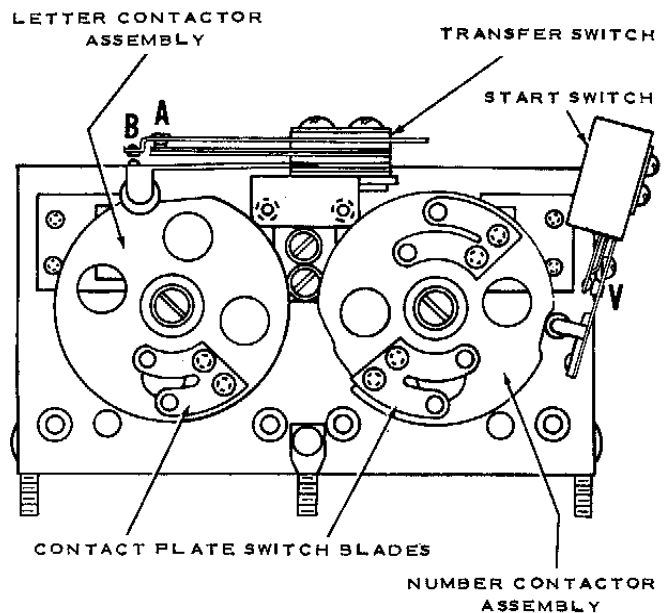

Figure 16.

- (c) Adjust contact "A" pressure 1 oz.
- (d) The second operation of the step magnet should result in closing contact "B" with 1 oz. pressure and opening contact "A" 1/64" to 1/32" gap.

### LUBRICATION

Lubricate with a drop of *Seeburg No. 53014 Special Purpose Oil*:

1. Pawl Pivots and sliding surfaces of the pawls on the step relay armatures.
2. Pawl guides at area of contact with pawls.
3. Step switch shaft bearings.
4. Roller on roller blade of transfer switch
5. Relay hinges.

# TORMAT SELECTION RECEIVER, TYPE TSR1-L6

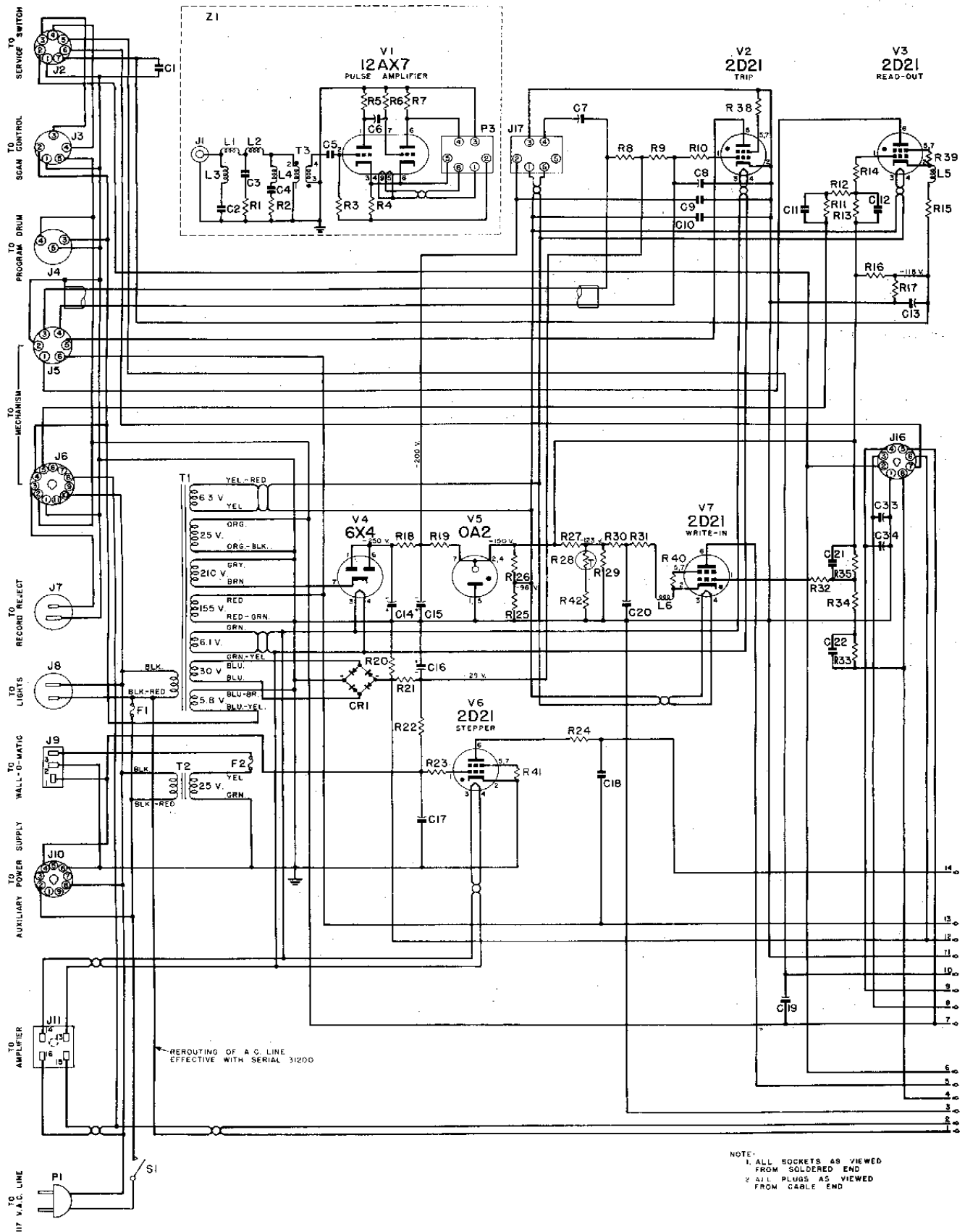

Figure 17. - Schematic Diagram

# TORMAT SELECTION RECEIVER, TYPE TSRI-L6

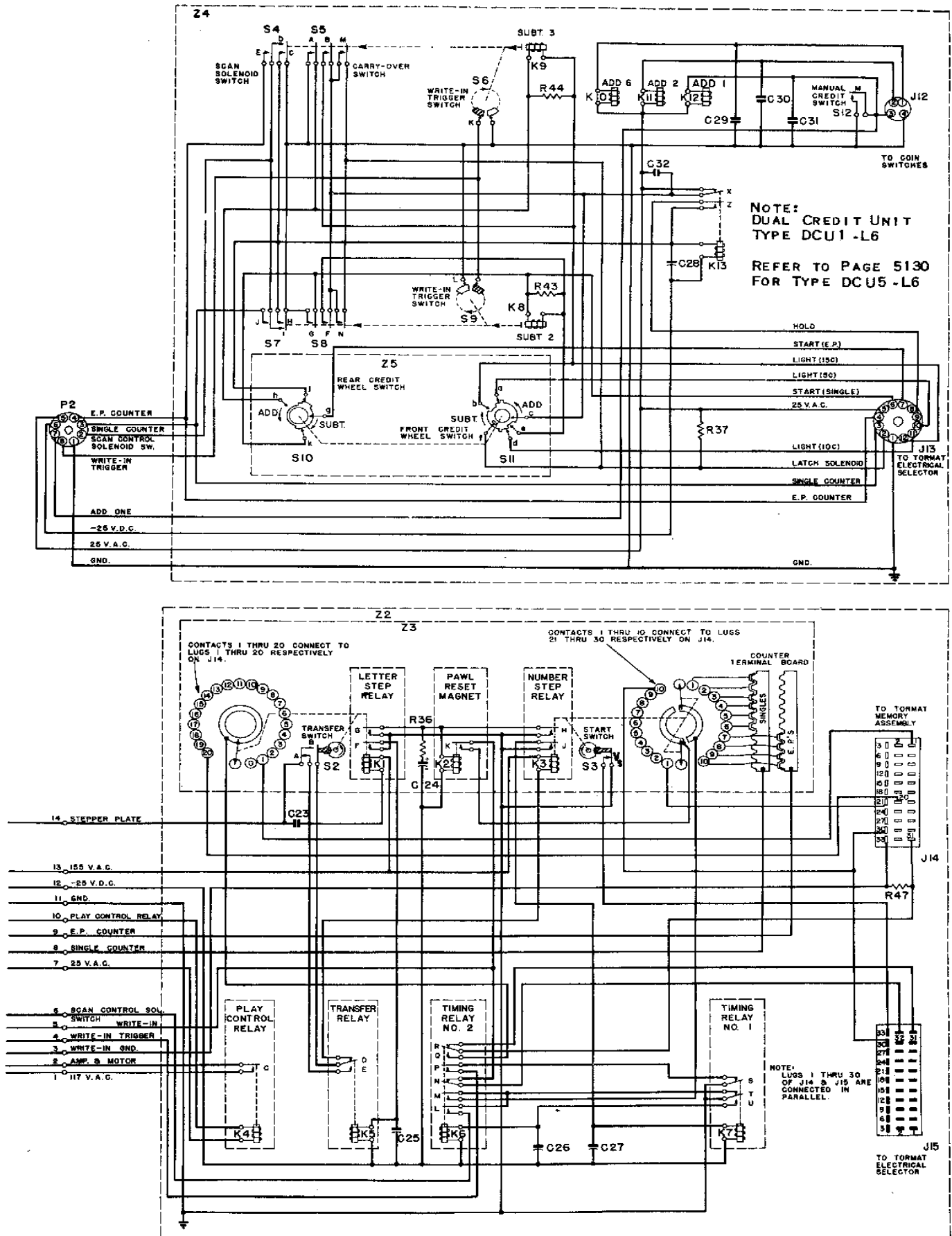
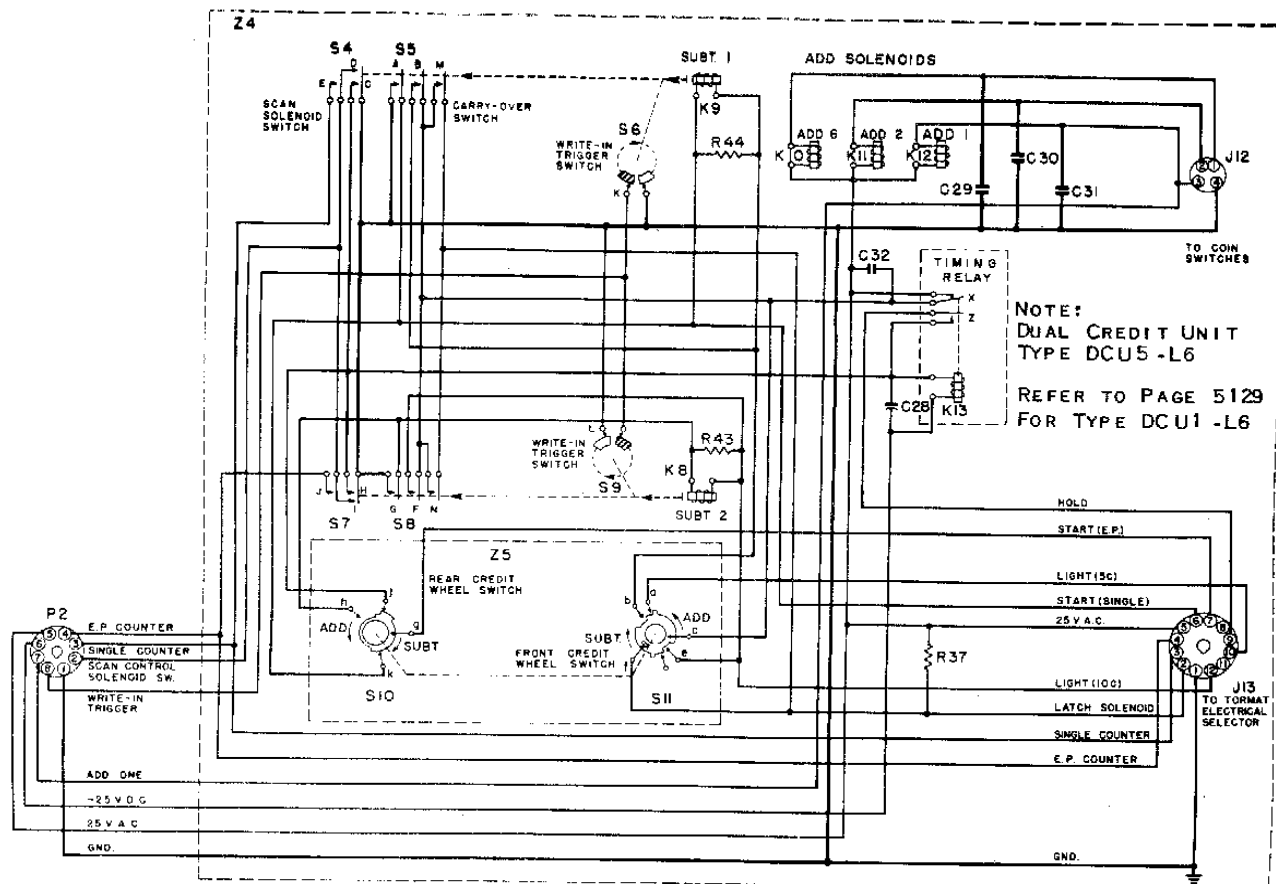

Figure 18. - Schematic Diagram

# TORMAT SELECTION RECEIVER, TYPE TSRI-L6



## PARTS LIST (For Figures 17 and 18)

Item	Part No.	Part Name	Item	Part No.	Part Name	Item	Part No.	Part Name
C1	86251	3000 mfd. 500 v. Ceramic	J17	301034	6 Prong Socket (Small)	R30	82448	100,000 Ohm ± 10% 1/2 W.
C2	86253	360 mfd. ± 10% 500 v. Ceramic	K1	303545	Letter Step Relay	R31	82618	100 Ohm ± 5% 1/2 W.
C3	86252	1200 mfd. ± 10% 500 v. Ceramic	K2	303541	Pawl Reset Magnet	R32	82448	100,000 Ohm ± 10% 1/2 W.
C4	86253	360 mfd. ± 10% 500 v. Ceramic	K3	303546	Number Step Relay	R33	82460	1.0 Megohm ± 10% 1/2 W.
C5	86251	3000 mfd. 500 v. Ceramic	K4	303077	Play Control Relay	R34	82440	22,000 Ohm ± 10% 1/2 W.
C6	86185	.05 mfd. ± 10% 200 v. Paper	K5	303074	Transfer Relay	R35	82444	47,000 Ohm ± 10% 1/2 W.
C7	86142	.1 mfd. 200 v. Paper	K6	303585	Timing Relay No. 2	R36	82403	18 Ohm ± 10% 1/2 W.
C8	86235	.05 mfd. 200 v. Paper	K7	303588	Timing Relay No. 1	R37	82707	1,200 Ohm ± 10% 1 W.
C9	86251	3000 mfd. 500 v. Ceramic	K8	450160	Subtract Two (2) Solenoid	R38	82440	22,000 Ohm ± 10% 1/2 W.
C10	86251	3000 mfd. 500 v. Ceramic	K9	*450158	Subtract Three (3) Solenoid	R39	82440	22,000 Ohm ± 10% 1/2 W.
C11	86254	5000 mfd. ± 10% 500 v. Ceramic		1450158	Subtract One (1) Solenoid	R40	82440	22,000 Ohm ± 10% 1/2 W.
C12	86255	2000 mfd. ± 10% 500 v. Ceramic	K10	450162	Add Six (6) Solenoid	R41	82440	22,000 Ohm ± 10% 1/2 W.
C13	86249	.1 mfd. ± 10% 200 v. Paper	K11	450152	Add Two (2) Solenoid	R42	82638	18,000 Ohm ± 5% 1/2 W.
C14	87615	40 mfd. 300 v. Lytic	K12	450154	Add One (1) Solenoid	R43	82838	100 Ohm ± 10% 2 W.
C15	87616	10 mfd. 300 v. Lytic	K13	450280	Timing Relay	R44	82838	100 Ohm ± 10% 2 W.
C16	87571	25 mfd. 50 v. Lytic	L1	303602	16 ohm Choke ± 5%	R47	82432	4700 Ohm ± 10% 1/2 W.
C17	86235	.05 mfd. 200 v. Paper	L2	303602	16 ohm Choke ± 5%	S1	303112	Toggle Switch S.P.S.T.
C18	11076	5 mfd. 300 v. Paper	L3	303600	11 ohm Choke ± 5%	S2	303547	Transfer Switch
C19	86142	.1 mfd. 200 v. Paper	L4	303600	11 ohm Choke ± 5%	S3	303625	Start Switch
C20	86165	.05 mfd. ± 10% 200 v. Paper	L5	303601	27 ohm Choke ± 5%	S4	*450149	Scan Solenoid Switch
C21	86255	2000 mfd. ± 10% 500 v. Ceramic	L6	303603	130 ohm Choke ± 5%	S5	1450210	Scan Solenoid Switch
C22	86250	5000 mfd. 1000 v. Ceramic	P1	303571	Line Cord & Plug Assembly	S6	*450150	Carry-Over Switch
C23	86250	5000 mfd. 1000 v. Ceramic	P2	12028	8 Prong Plug	S7	1450211	Carry-Over Switch
C24	87611	300 mfd. 50 v. Lytic	P3	303599	6 Prong Plug	S8	1450255	Contact Assembly
C25	86235	.05 mfd. 200 v. Paper	R1	82409	56 Ohm ± 10% 1/2 W.	S9	1450105	Contact Segment Assembly
C26	86235	.05 mfd. 200 v. Paper	R2	82409	56 Ohm ± 10% 1/2 W.	S10	450149	Scan Solenoid Switch
C27	86235	.05 mfd. 200 v. Paper	R3	82444	47,000 Ohm ± 10% 1/2 W.	S11	840150	Carry-Over Switch
C28	86142	.1 mfd. 200 v. Paper	R4	82610	6280 Ohm ± 5% 1/2 W.	S12	1450272	Contact Assembly
C29	86258	.04 mfd. 500 v. Ceramic	R5	82456	47,000 Ohm ± 10% 1/2 W.	S10	1450132	Contact Segment Assembly
C30	86259	.02 mfd. 500 v. Ceramic	R6	82469	5.6 Megohm ± 10% 1/2 W.	S11	*450089	Rear Credit Wheel Switch Assembly
C31	86258	.04 mfd. 500 v. Ceramic	R7	82640	27,000 Ohm ± 5% 1/2 W.	S10	1450334	Rear Credit Wheel Switch Assembly
C32	86259	.02 mfd. 500 v. Ceramic	R8	82464	2.2 Megohm ± 10% 1/2 W.	S11	*450140	Front Credit Wheel Switch Assembly
C33	86142	0.1 mfd. 200 v. Paper	R9	82464	2.2 Megohm ± 10% 1/2 W.	S10	1450342	Front Credit Wheel Switch Assembly
C34	86142	0.1 mfd. 200 v. Paper	R10	82456	47,000 Ohm ± 10% 1/2 W.	S12	450244	Manual Credit Switch
CR1	400587	Selenium Rectifier	R11	82465	2.7 Megohm ± 10% 1/2 W.	T1	303567	Power Transformer
F1	602411	5 Amp. Fuse, Type 3AG	R12	82440	22,000 Ohm ± 10% 1/2 W.	T2	303569	25 v. Transformer
F2	301205	3 Amp. Fusistat fuse	R13	82444	47,000 Ohm ± 10% 1/2 W.	T3	303455	Pulse Transformer
F3	300152	Single Prong Socket	R14	82448	100,000 Ohm ± 10% 1/2 W.		or	
J2	84282	7 Prong Socket	R15	81130	0.47 Ohm ± 5% W.W. 1/2 W.	V1	303457	Pulse Transformer (Alternate)
J3	84283	5 Prong Socket	R16	82698	150,000 Ohm ± 5% 1/2 W.	V2	308120	12AX7 Vacuum Tube
J4	303555	3 Prong Socket (Small)	R17	82781	560,000 Ohm ± 5% 1/2 W.	V3	308006	2021 Thyatron
J5	84223	6 Prong Socket (Small)	R18	82805	2200 Ohm ± 10% 2 W.	V3	308006	2021 Thyatron
J6	303253	11 Prong Socket	R19	82836	2700 Ohm ± 10% 2 W.	V4	308626	6X4 Vacuum Tube
J7	602839	2 Prong Socket (Small)	R20	82432	4700 Ohm ± 10% 1/2 W.	V5	308005	0A2 V. R. Tube
J8	13401	2 Prong Socket (Small)	R21	82448	100,000 Ohm ± 10% 1/2 W.	V6	308006	2021 Thyatron
J9	12006	3 Prong Socket	R22	82448	100,000 Ohm ± 10% 1/2 W.	V7	308006	2021 Thyatron
J10	84244	9 Prong Socket	R23	82436	10,000 Ohm ± 10% 1/2 W.	Z1	303590	Pulse Amplifier
J11	301020	4 Prong Socket	R24	82716	100 Ohm ± 10% 1 W.	Z2	303520	Relay & Step Switch Assembly
J12	84293	4 Prong Socket (Small)	R25	82454	330,000 Ohm ± 10% 1/2 W.	Z3	303510	Step Switch Assembly
J13	84301	12 Prong Socket	R26	82451	180,000 Ohm ± 10% 1/2 W.	Z4	*450000	Dual Credit Unit
J14	303528	33 Prong Socket	R27	82637	15,000 Ohm ± 5% 1/2 W.	Z5	1450002	Dual Credit Unit
J15	303529	33 Prong Plug	R28	303633	Thermistor		450078	Credit Wheel Assembly
J16	84292	8 Prong Socket	R29	82667	470,000 Ohm ± 5% 1/2 W.			

\* Used on Dual Credit Unit, Type DCU1-L6

† Used on Dual Credit Unit, Type DCU5-L6

TORMAT SELECTION RECEIVER, TYPE TSR1-L6

PARTS LIST

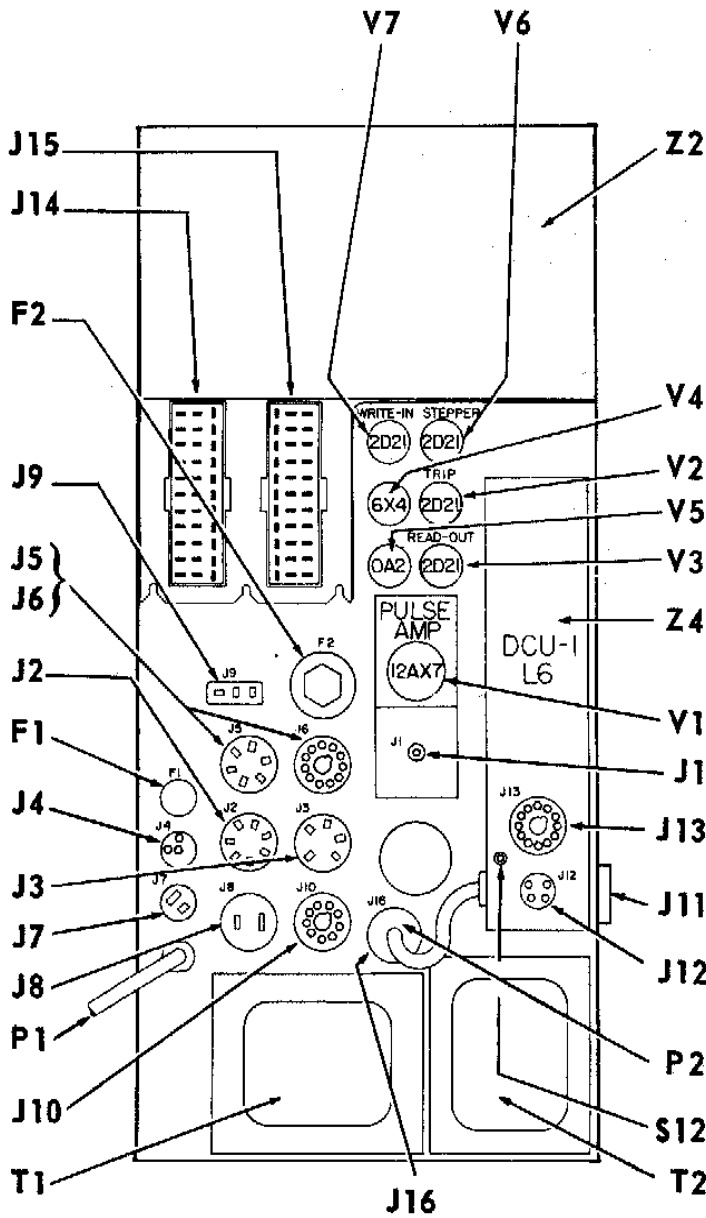

Figure 19.

Item	Part No.	Part Name
F1	602411	5 Amp. Fuse, Type 3AG
F2	301205	3 Amp. Fustat Fuse
J1	300152	Single Prong Socket
J2	84282	7 Prong Socket
J3	84283	5 Prong Socket
J4	303555	3 Prong Socket (Small)
J5	84223	6 Prong Socket
J6	303253	11 Prong Socket
J7	602839	2 Prong Socket (Small)
J8	11401	2 Prong Socket
J9	12006	3 Prong Socket
J10	84244	9 Prong Socket
J11	301020	4 Prong Socket
J12	84293	4 Prong Socket (Small)
J13	84301	12 Prong Socket
J14	303528	33 Prong Socket
J15	303529	33 Prong Plug
J16	84292	8 Prong Socket
P1	303571	Line Cord & Plug Assembly
P2	12028	8 Prong Plug
S12	450244	Manual Credit Switch
T1	303567	Power Transformer
T2	303569	25 v. Transformer
V1	308120	12AX7 Vacuum Tube
V2	308006	2D21 Thyatron
V3	308006	2D21 Thyatron
V4	308626	6X4 Vacuum Tube
V5	308005	0A2 V. R. Tube
V6	308006	2D21 Thyatron
V7	308006	2D21 Thyatron
Z2	303520	Relay & Step Switch Assembly
Z4	450000	Dual Credit Unit

TORMAT SELECTION RECEIVER, TYPE TSR1-L6

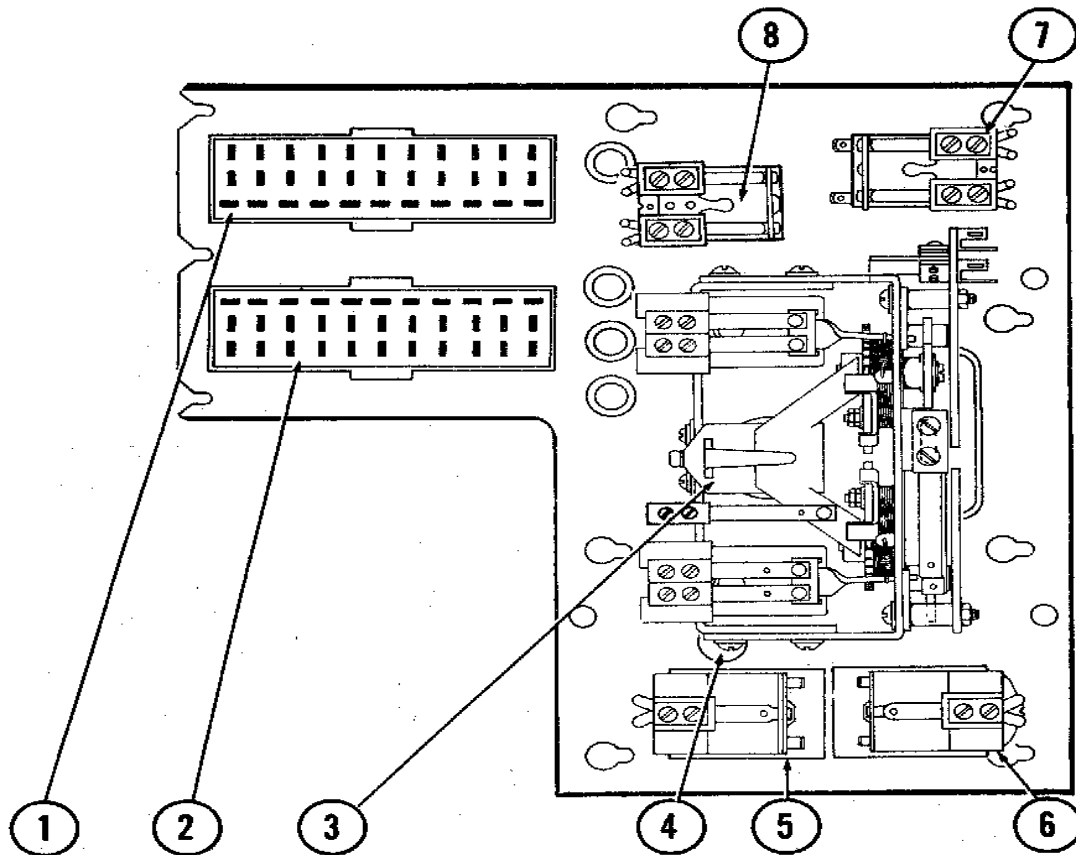

Figure 20. No. 303520 Step Switch & Relay Assembly

PARTS LIST

Item	Part No.	Part Name
1	303528	33 Prong Socket (J14)
2	303529	33 Prong Plug (J15)
3	303510	Step Switch Assembly (Z3)
4	10848	Cup Washer
	988290	Grommet (Rubber)
5	303077	Play Control Relay (K4)
	303128	Coil & Frame Assembly
	303127	Contact Assembly (C)
6	303074	Transfer Relay (K5)
	303130	Coil & Frame Assembly
	303129	Contact Assembly (D & E)
7	303588	Timing Relay No. 1 (K7)
	303617	Coil & Frame Assembly
	303616	Contact Assembly (T & U)
	303615	Contact Assembly (S)
8	303589	Timing Relay No. 2 (K6)
	303620	Coil & Frame Assembly
	303618	Contact Assembly (N, M & L)
	303619	Contact Assembly (R, Q & P)

TORMAT SELECTION RECEIVER, TYPE TSRI-L6

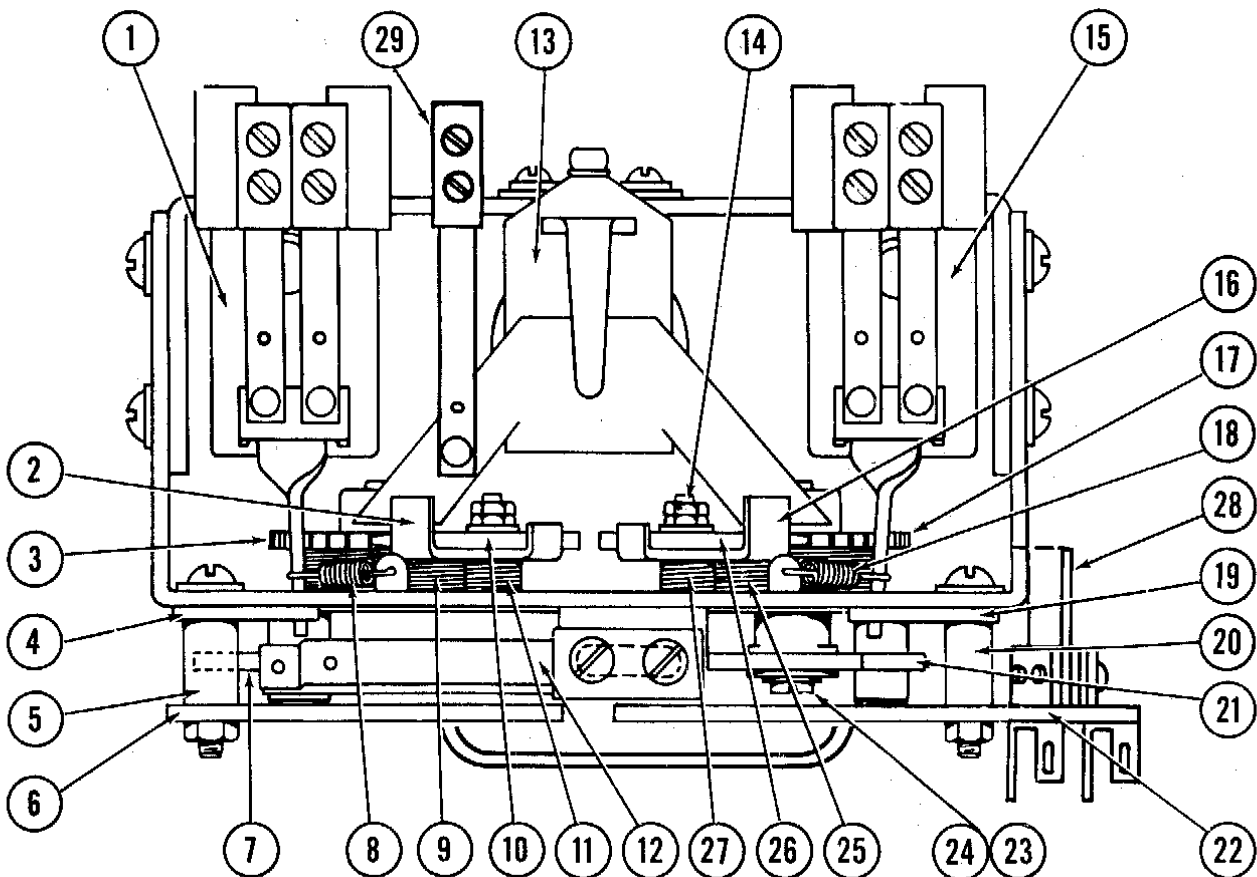

Figure 21. No. 303510 Assembly

PARTS LIST

ITEM	PART NO.	PART NAME	ITEM	PART NO.	PART NAME
1	303545	LETTER STEPPER RELAY ASSEM. (INCLUDES THE FOLLOWING 6 ITEMS)	14	303185	2- 56 HEX NUTS
	303540	MAGNET & FRAME ASSEMBLY		303186	NO. 2 WASHERS (UNDER NUTS)
	303100	ARMATURE ASSEMBLY	15	303546	NUMBER STEPPER RELAY ASSEMBLY (INCLUDES THE FOLLOWING 5 ITEMS)
	303102	TAIL SPRING		303542	MAGNET & FRAME ASSEMBLY
	303192	STEPPER SWITCH ASSEMBLY (CONTACT G & F)		303101	ARMATURE ASSEMBLY
	303191	SWITCH MOUNTING SCREWS (3- 48 X 11/ 32 R.H.M.S.)		303102	TAIL SPRING
	303176	SWITCH MOUNTING BRACKET		303192	STEPPER SWITCH ASSEMBLY (CONTACT J & H)
2	303177	DOG OPERATING LINK		303191	SWITCH MOUNTING SCREWS (3- 48 X 11/ 32)
3	303179	RATCHET AND SHAFT	16	303178	DOG OPERATING LINK
4	303187	PAWL GATE	17	303538	RATCHET & SHAFT
5	303188	CONTACT PLATE SPACER	18	303106	PAWL RETURN SPRING
6	303543	CONTACT PLATE	19	303187	PAWL GATE
7	303071	CONTACTOR	20	303188	CONTACT PLATE SPACER
	303184	CONTACTOR MOUNTING WASHER (NOT SHOWN)	21	303536	CONTACTOR
	303183	CONTACTOR MOUNTING SCREW (NOT SHOWN)	22	303544	CONTACT PLATE
8	303106	PAWL RETURN SPRING	23	303184	CONTACTOR MOUNTING WASHER
9	303104	RETURN SPRING	24	303183	CONTACTOR MOUNTING SCREW
10	303181	DOG	25	303537	RETURN SPRING
11	303107	DOG RETURN SPRING	26	303181	DOG
12	303548	TRANSFER SWITCH ASSEMBLY (INCLUDES THE FOLLOWING 4 ITEMS)	27	303108	DOG SPRING
	303117	SWITCH MOUNTING BRACKET	28	303624	START SWITCH ASSEMBLY (INCLUDES THE FOLLOWING 4 ITEMS)
	303182	SWITCH MOUNTING SCREWS (5- 40 X 9/ 16 R.H.M.S.)		303626	SWITCH MOUNTING BRACKET
	303547	TRANSFER SWITCH (CONTACTS A AND B)		910940	SWITCH MOUNTING SCREWS (3- 48 X 7/ 16 R.H.M.S.)
	303189	SWITCH RETAINER PLATE		303625	START SWITCH (CONTACT V)
13	303541	PAWL RELEASE MAGNET, COMPLETE		450259	SWITCH RETAINER PLATE
	303103	TAIL SPRING, ONLY	29	303621	RESET MAGNET SWITCH ASSEMBLY (INCLUDES THE FOLLOWING 3 ITEMS)
				303623	SWITCH MOUNTING BRACKET
				910998	SWITCH MOUNTING SCREWS (3- 48 X 11/ 16 R.H.M.S.)
				303622	RESET SWITCH (CONTACT K)

TORMAT SELECTION RECEIVER, TYPE TSRI-L6

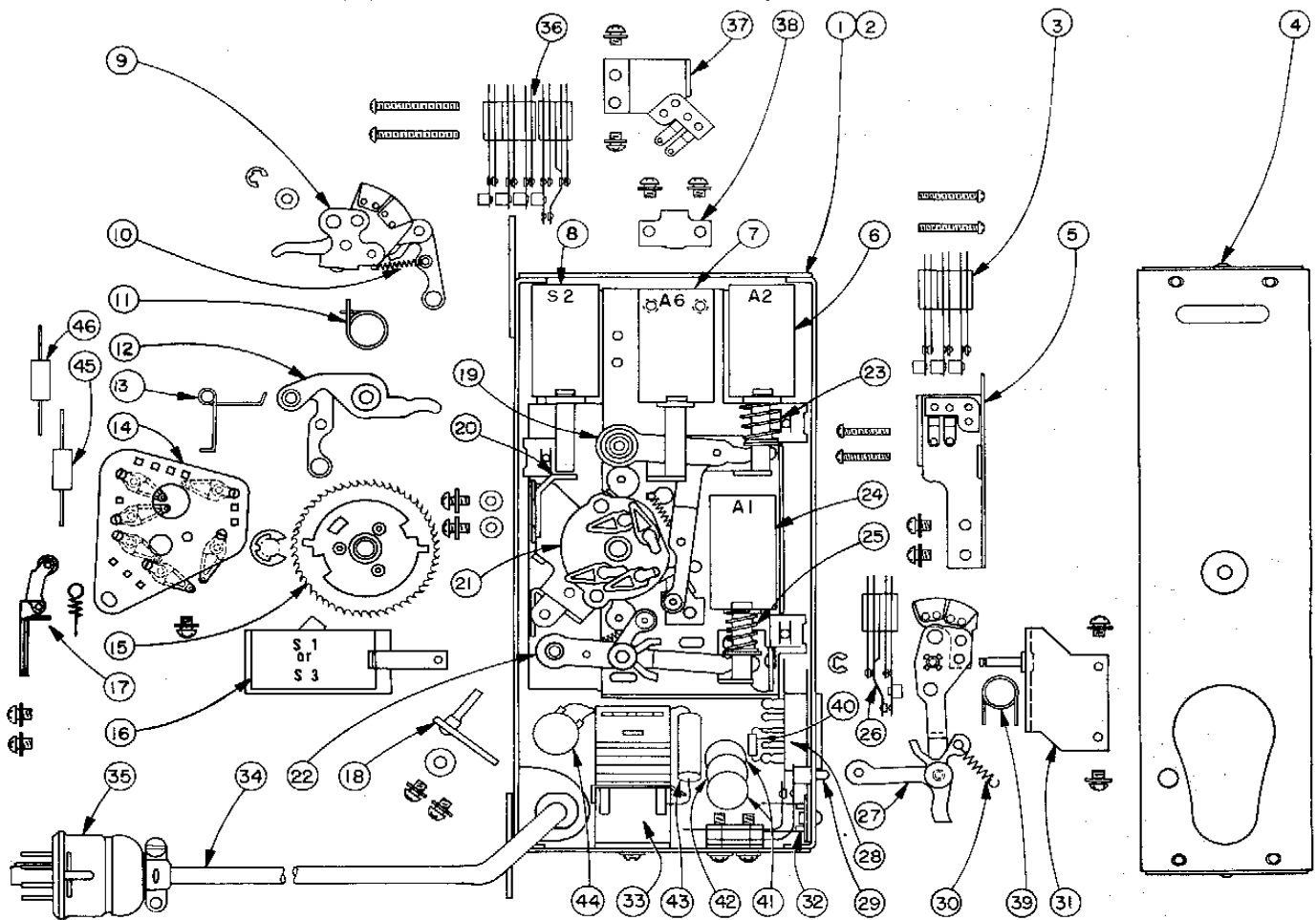

Figure 22. Dual Credit Unit Assemblies

PARTS LIST

Item	Part No.	Part Name	Item	Part No.	Part Name
1	* 450000	COMPLETE UNIT	19	450111	CREDIT ARM ASSEMBLY (ADD 2)
	† 450002	COMPLETE UNIT		450129	SPRING
2	450022	MOUNTING PLATE STAKED ASSEMBLY	20	450102	PLUNGER STOP BRACKET (SUB 2)
3	* 450150	CARRY-OVER SWITCH		912859	SEMS
	† 450211	CARRY-OVER SWITCH	21	450089	TERMINAL BOARD ASSEMBLY
	450259	TAPPED PLATE	22	450085	CREDIT ARM ASSEMBLY (ADD 1)
	450260	TENSION PLATE		450086	SPRING
4	* 450247	3-48 X 3/8 PHILLIPS R.H.M.S.	23	450329	SPRING
	† 450297	COVER ASSEMBLY	24	450184	COIL & BRACKET ASSEMBLY (ADD 1)
	450254	COVER ASSEMBLY		450075	SOLENOID PLUNGER ASSEMBLY
5	450254	SWITCH MOUNTING BRACKET		912882	SEMS
	† 450344	SWITCH MOUNTING BRACKET ASSEMBLY (SUB 1)	25	450329	SPRING
	912882	SEMS	26	* 450149	SWITCH
6	450192	COIL & BRACKET ASSEMBLY (ADD 2)		† 450210	SWITCH
	450075	SOLENOID PLUNGER ASSEMBLY		450259	TAPPED PLATE
	912882	SEMS		450260	TENSION PLATE
7	450186	CREDIT COIL & BRACKET ASSEMBLY (ADD 6)		911011	3-48 X 1/2 PHILLIPS R.H.M.S.
	450074	SOLENOID PLUNGER ASSEMBLY	27	* 450105	CANCEL ARM ASSEMBLY (SUB 3)
	912882	SEMS		† 450339	CANCEL ARM ASSEMBLY
8	450190	CANCEL COIL & BRACKET ASSEMBLY (SUB 2)	28	84201	12 PRONG SOCKET
	450075	SOLENOID PLUNGER ASSEMBLY	29	450244	MANUAL CREDIT SWITCH
	912882	SEMS		912843	SEMS
9	450132	CANCEL ARM ASSEMBLY (SUB 2)		200026	TAPPED PLATE
	125448	RETAINING RING	30	450129	SPRING
	921112	WASHER	31	* 450037	PIVOT BRACKET ASSEMBLY
10	450096	SPRING		† 450332	PIVOT BRACKET ASSEMBLY
11	450130	TORSION SPRING		912882	SEMS
12	450121	CREDIT ARM ASSEMBLY (ADD 6)	32	84293	4 PRONG SOCKET
13	450131	SPRING - TORSION	33	450280	TIMING RELAY
				914225	SEMS
14	* 450140	CONTACT PLATE ASSEMBLY	34	450245	CABLE ASSEMBLY
	† 450342	CONTACT PLATE ASSEMBLY	35	12028	OCTAL PLUG
	912859	SEMS	36	450150	SWITCH (CARRY-OVER)
15	450078	CREDIT WHEEL ASSEMBLY		450149	SWITCH
	125403	RETAINING RING		3-48 X 1/2 PHILLIPS R.H.M.S.	
16	* 450188	COIL & BRACKET ASSEMBLY (SUB 3)	37	450261	SWITCH MOUNTING BRACKET ASSEMBLY (SUB 2)
	† 450338	CANCEL COIL & BRACKET ASSEMBLY (SUB 1)		912882	SEMS
	912882	SEMS	38	450318	RESIDUAL SPRING
	* 450075	SOLENOID PLUNGER ASSEMBLY		912810	6-32 X 1 7/8 PHILLIPS R.H.M.S.
	† 450348	SOLENOID PLUNGER ASSEMBLY		450317	RESIDUAL PIN
	450465	DETENT ROLLER ASSEMBLY	39	928342	FLAT WASHER
	450464	DETENT SPRING ONLY	40	450251	TORSION SPRING
	910821	3-48 X 3/16 PHILLIPS P.H.M.S.		82707	1200 OHM 1 W. RESISTOR
18	450326	STOP PIN PLATE ASSEMBLY	41	86259	.02 CERAMIC CONDENSER
	920739	FLAT WASHER	42	86258	.04 CERAMIC CONDENSER
	912888	SEMS	43	86142	.1 MFD. 200 V CONDENSER
			44	86259	.02 MFD. CERAMIC CONDENSER
			45	82838	100 OHM 2 W. RESISTOR

\* USED ON TYPE DCU1-L6

† USED ON TYPE DCU5-L6



## TORMAT SELECTION RECEIVER TYPE TSR2-L6

The Tormat Selection Receiver, Type TSR2-L6, is the power distribution and control center of the Select-O-Matic "200" R. C. Special, Model HV-200 for operation from wired Wall-O-Matics, Type V-3WA. Power enters the Receiver through the line cord and main switch and is distributed, directly at 117-volts or through transformers, to the Select-O-Matic Mechanism, the cabinet lighting, the amplifier, and the Wall-O-Matics. All connections to the Receiver are made with plugs which are of different types and sizes to avoid possibility of incorrect connections. Included in the Receiver are a Step Switch and Relay Assembly, and a 2D21 tube, for selection of records from Wired Wall-O-Matics.

A 25-volt transformer supplies power for up to six Type V-3WA Wall-O-Matics. Another transformer, the selection receiver power transformer, has seven output windings for control circuits, and heater current for the tubes in the High Fidelity Master Amplifier.

One of the secondaries of the selection receiver power transformer provides approximately 30-volts, a.c. This 30-volt output is rectified by a full-wave selenium rectifier for 25-volt d.c. supply for some of the relays of the Step Switch and Relay Assembly, and for bias supply for the 2D21 tube. Another secondary provides approximately 150-volts for operating the step switches through the plate circuit of the 2D21 tube.

Operation of Selection Receiver, Type TSR2-L6, is the same as that of the Type TSR1-L6. All service notes, schematic diagrams, and parts lists applying to the Type TSR1-L6 apply to the Type TSR2-L6 except that there is no Dual Credit Unit incorporated for operation of an electrical selector. The space on the chassis of the TSR2-L6 is used for a Selection Counter Assembly, Part No. 303656. The parts list for this assembly is given below.

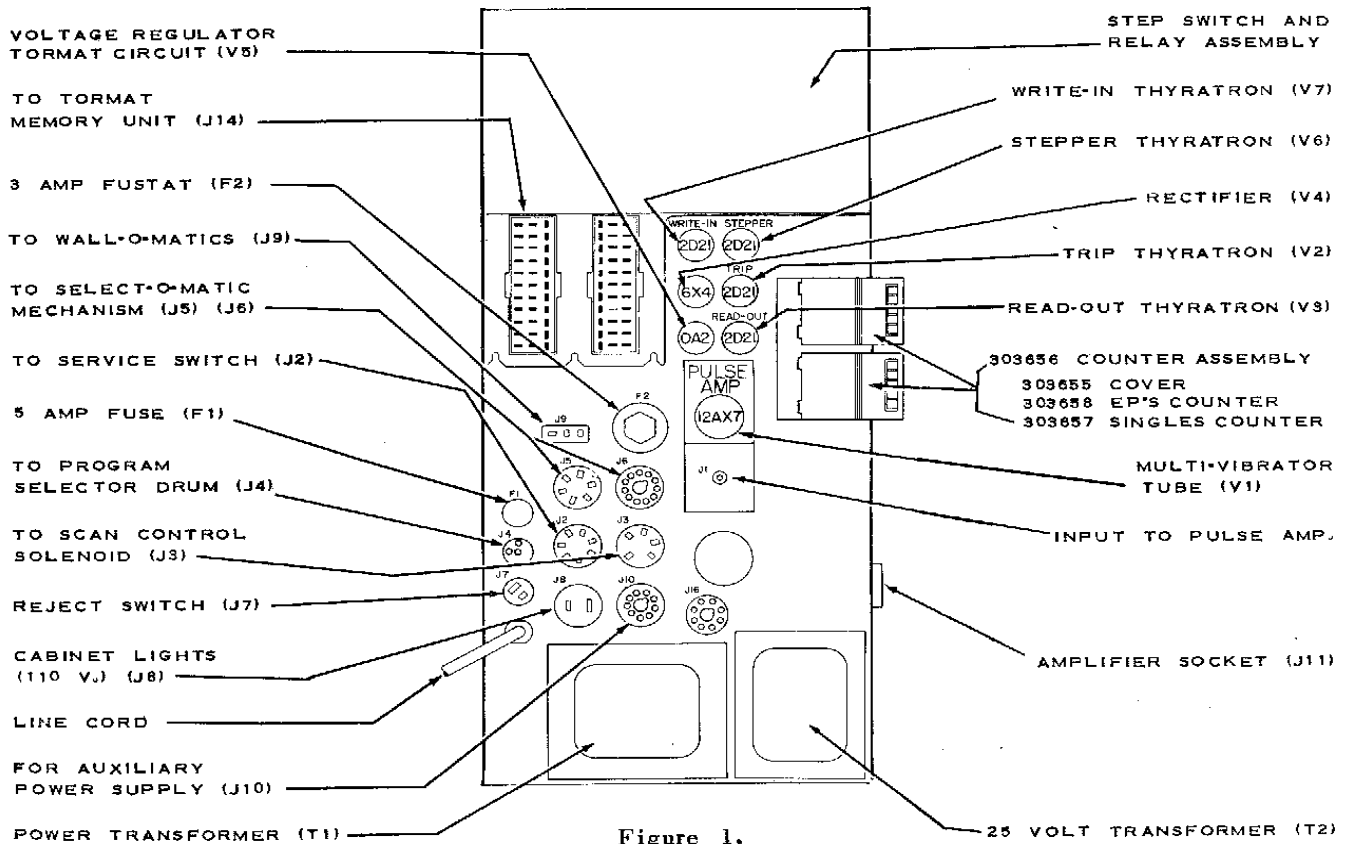

Figure 1.



# TORMAT SELECTION RECEIVER TYPE TSR3-L6

The Tormat Selection Receiver, Type TSR3-L6 is the power distribution and control center for operation of the Select-O-Matic mechanism and the Tormat Memory System from the Electrical Selector at the phonograph or by remote control with 200-selection, 3-wire, Wall-O-Matics. Power enters the Receiver through the line cord and main switch and is distributed, at 117 volts or through transformers, to the Electrical Selector, the Select-O-Matic Mechanism, cabinet lighting, program selector, amplifier and the Wall-O-Matics. All connections to the Receiver are made with plugs and connectors of different types and sizes to avoid possibility of incorrect connections.

Included in the Receiver are a Step Switch and Relay Assembly, a Dual Credit Unit and a pulse amplifier unit. The Step Switch and Relay Assembly and a 2050 thyratron, V6, are for step relay operation for selection from the Wall-O-Matics. The Dual Credit Unit incorporates an accumulative add-and-subtract credit switch for credit and selection control at the phonograph. The pulse amplifier in-

cludes a 12AX7 tube, V1, that amplifies the trip signal from the output loop of the Tormat Memory Unit on the Select-O-Matic Mechanism. The pulse from the 12AX7 tube controls a 2050 thyratron, V2, which in turn passes current for operation of the trip solenoid of the Select-O-Matic mechanism.

A 6X4 rectifier tube, V3, supplies ground-ed-positive plate power for the 12AX7 pulse amplifier and, with two OA2 regulator tubes, J4 and J5, regulated voltage supply for charging condensers from which are taken power for the write-in and read-out pulses to the Tormat Memory Unit.

A full wave selenium rectifier supplies d.c. at approximately 25 volts for some of the relays of the Step Switch Assembly and a timing relay in the Dual Credit Unit and for grid bias of the 2050 tubes for the trip solenoid and step relays.

All of the mechanism control circuits, plate and bias supplies and tube heater circuits are supplied from the multiple-secondary transformer, T1.

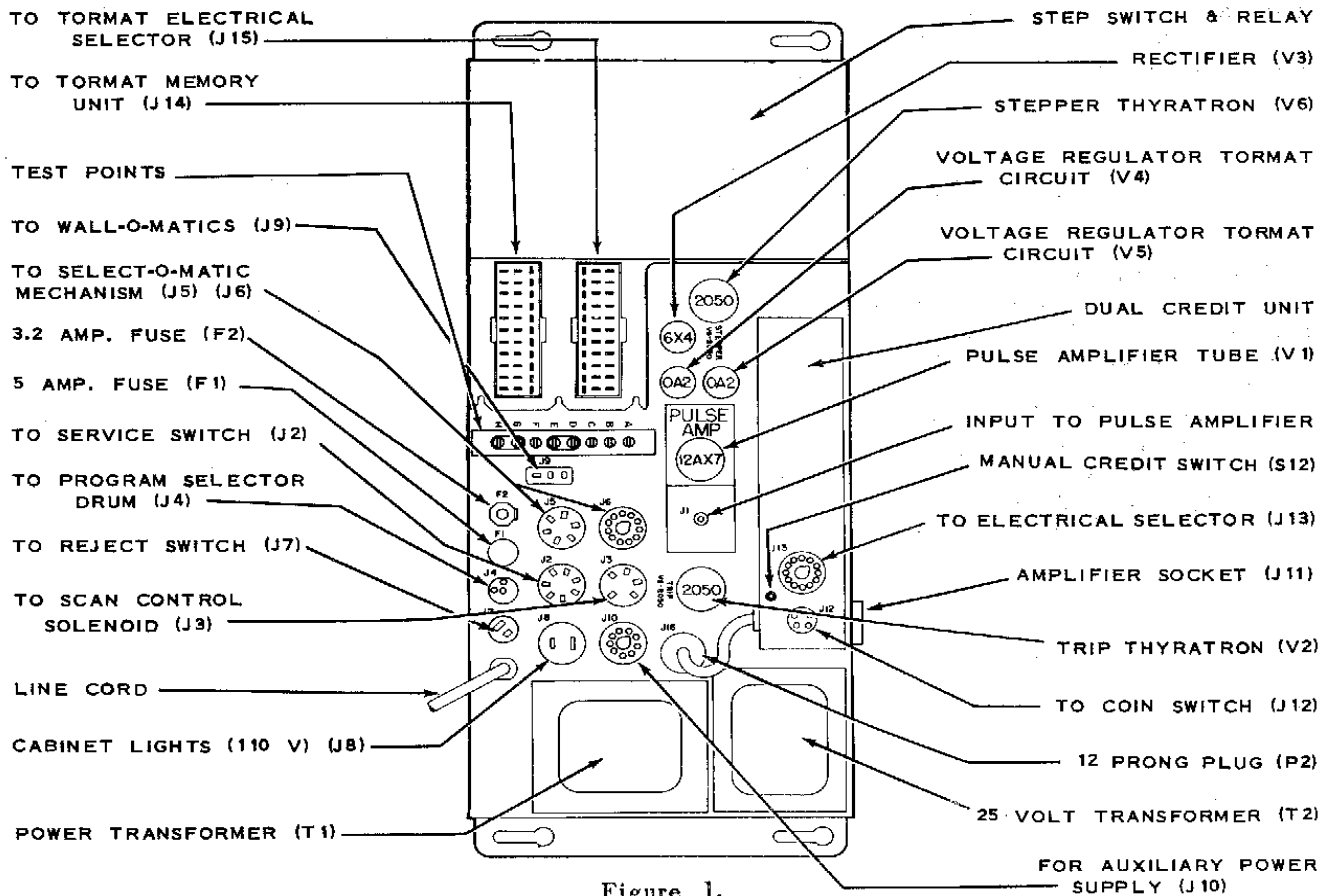

Figure 1.

## TORMAT SELECTION RECEIVER, TYPE TSR3-L6

The Dual Credit Unit and the pulse amplifier connect to the circuits of the Receiver with plugs and sockets. They may be removed for test or service. Access to the interior wiring of the Receiver is had, while it is operating in normal position, by removing the cover plate on the outside of the rear door of the phonograph. To remove the cover plate, take off the three wind-nuts located inside the door just above the amplifier and selection receiver and loosen the screw at the center of the bottom edge of the plate. After removing the nuts, pull out on

the plate so the three bolts are out of the holes in the door and lift up on the plate to disengage it at the lower edge.

The Selection Receiver may be removed from its mounting by removing the cover plate and loosening the four screws holding the flanges of the unit. With the four screws loosened, slide the unit away from the amplifier to disengage the locating pins and amplifier socket connection. It may then be lifted from the mounting frame.

### DUAL CREDIT UNIT, TYPE DCU1L-L6, TYPE DCU5L-L6

The Dual Credit Units are part of the Tormat Memory System for making selections for coins deposited at the phonograph. The Type DCU1L-L6 is the same, functionally, as the Type DCU1-L6 that is discussed beginning on page 5138. The DCU1-L6 and the DCU1L-L6 differ in respect to the write-in trigger switch connections and in the cable and plug that connects the Unit to the Tormat Selection Receiver. The trigger switches, contacts K and L, in the DCU1L-L6 terminate at pins 8 and 9 of a 12-prong plug (for connection to the Receiver) instead of pins 8 and 1 (ground) as shown in the diagram, *Figure 5*, on page 5117. The

12-prong plug and all DCU1L-L6 wiring are shown in the complete diagram for the Type TSR3-L6 Selection Receiver on page 5140 and 5141.

The Dual Credit Units Type DCU1L-L6 and Type DCU5L-L6 differ in that the latter is designed for use in selection pricing of five cents and ten cents instead of ten cents and fifteen cents as with the DCU1L-L6 (and DCU1-L6). All adjustments of the two types are identical as shown on pages 5122 to 5124. The internal wiring and connections for the DCU5L-L6 is shown on page 5142.

### STEP SWITCH AND RELAY ASSEMBLY OPERATION

The Step Switch and Relay Assembly in the Type TSR3-L6 Selection Receiver operates the same as the Assembly in the TSR1-L6 as described beginning on page 5118. In the TSR3-L6, however, the stepper thyatron is a type 2050 instead of a 2D21 as shown at V6 in the diagram, *Figure 7*, page 5120. Also, in the Type TSR3-L6, the S and P contacts of the timing relays operate in a simple switching circuit to control, directly, the write-in current

pulse to the Tormat Memory Unit instead of triggering the write-in 2D21, V7, *Figure 7*. (A write-in thyatron is not used in the Type TSR3-L6.) The complete diagram of the Assembly and its connections in the remote control selection system is shown in the Selection Receiver diagram, page 5140 and 5141. All adjustments of the Assembly in the TSR3-L6 are the same as for the TSR1-L6 beginning on page 5126.

TORMAT SELECTION RECEIVER, TYPE TSR3-L6

**PARTS LIST**  
(For Pages 5140 and 5141)

Item	Part No.	Part Name	Item	Part No.	Part Name
C1	86251	3000 MMF 500 V. CERAMIC	L6	303601	27 <i>ub</i> CHOKE ± 5%
C2	86253	360 MMF ± 10% 500 V. CERAMIC	P1	303571	LINE CORD & PLUG ASSEMBLY
C3	86252	1200 MMF ± 10% 500 V. CERAMIC	P2	410707	12 PRONG PLUG
C4	86253	360 MMF ± 10% 500 V. CERAMIC	P3	303599	6 PRONG PLUG
C5	86251	3000 MMF 500 V. CERAMIC	R1	82409	56 OHM ± 10% ½ W.
C6	86030	.05 MFD ± 10% 400 V. PAPER	R2	82409	56 OHM ± 10% ½ W.
C7	86248	.15 MFD ± 10% 200 V. PAPER	R3	82444	47,000 OHM ± 10% ½ W.
C8	86235	.05 MFD 200 V. PAPER	R4	82610	6200 OHM ± 5% ½ W.
C9	86251	3000 MMF 500 V. CERAMIC	R5	82456	470,000 OHM ± 10% ½ W.
C10	86251	3000 MMF 500 V. CERAMIC	R6	82469	5.6 MEGOHM ± 10% ½ W.
C11	86255	2000 MMF 500 V. CERAMIC	R7	82640	27,000 OHM ± 5% ½ W.
C12	87637	10 MFD 450 V. LYTIC	R8	82460	1.0 MEGOHM ± 10% ½ W.
C13	86296	.15 MFD ± 10% 600 V. PAPER	R9	82440	22,000 OHM ± 10% ½ W.
C14	87635	15 MFD 450 V. LYTIC	R10	82456	470,000 OHM ± 10% ½ W.
C15	87635	15 MFD 450 V. LYTIC	R11	82695	56,000 OHM ± 5% ½ W.
C16	87571	25 MFD 50 V. LYTIC	R12	82449	120,000 OHM ± 10% ½ W.
C17	86235	.05 MFD 200 V. PAPER	R13	82464	2.2 MEGOHM ± 10% ½ W.
C18	11076	5 MFD 300 V. PAPER	R14	82815	100,000 OHM ± 10% 2 W.
C19	86142	.1 MFD 200 V. PAPER	R15	81189	1.0 OHM ± 5% W.W. ½ W.
C20	86295	.068 MFD ± 10% 600 V. PAPER	R16	82993	36 OHM ± 5% ½ W.
C21	87636	10 MFD 150 V. LYTIC	R17	82440	22,000 OHM ± 10% ½ W.
C22	86212	.01 MFD 400 V. PAPER	R18	81190	3,300 OHM ± 10% W.W. 5 W.
C23	86250	5000 MMF 1000 V. CERAMIC	R19	82836	2,700 OHM ± 10% 2 W.
C24	87611	300 MFD 50 V. LYTIC	R20	82432	4,700 OHM ± 10% ½ W.
C25	86235	.05 MFD 200 V. PAPER	R21	82456	470,000 OHM ± 10% ½ W.
C26	86235	.05 MFD 200 V. PAPER	R22	82448	100,000 OHM ± 10% ½ W.
C27	86235	.05 MFD 200 V. PAPER	R23	82436	10,000 OHM ± 10% ½ W.
C28	86142	.1 MFD 200 V. PAPER	R24	82716	100 OHM ± 10% 1 W.
C29	86258	.04 MFD 500 V. CERAMIC	R25	82454	330,000 OHM ± 10% ½ W.
C30	86259	.02 MFD 500 V. CERAMIC	R26	82451	180,000 OHM ± 10% ½ W.
C31	86258	.04 MFD 500 V. CERAMIC	R27	82698	150,000 OHM ± 5% ½ W.
C32	86259	.02 MFD 500 V. CERAMIC	R28	82611	3000 OHM ± 5% ½ W.
C33	86252	1200 MMF ± 10% 500 V. CERAMIC	R29	82992	120,000 OHM ± 10% 1 W.
C34	86251	3000 MMF 500 V. CERAMIC	R30	82617	47 OHM ± 5% ½ W.
CR1	400587	SELENIUM RECTIFIER	R31	81189	1.0 OHM ± 5% W.W. ½ W.
CR2	303696	IN368 GERMANIUM DIODE	R32	303694	Positive Temp. Coeff. Resistor
F1	602411	5 AMP. FUSE, TYPE MTH	R33	82617	47 OHM ± 5% ½ W.
F2	303697	3.2 AMP. FUSE TYPE N 3-2/10	R34	82440	22000 OHM ± 10% ½ W.
J1	300152	SINGLE PRONG SOCKET	R35	82432	4700 OHM ± 10% ½ W.
J2	84282	7 PRONG SOCKET	R36	82403	18 OHM ± 10% ½ W.
J3	84283	5 PRONG SOCKET	R37	82707	1200 OHM ± 10% 1 W.
J4	303555	3 PRONG MIN. SOCKET	R38	82432	4700 OHM ± 10% ½ W.
J5	84223	6 PRONG SOCKET	R43	82838	100 OHM ± 10% 2 W.
J6	303253	11 PRONG SOCKET	R44	82838	100 OHM ± 10% 2 W.
J7	602839	2 PRONG SOCKET (Small)	S1	303112	TOGGLE SWITCH, S.P.S.T.
J8	11401	2 PRONG SOCKET	S2	303547	TRANSFER SWITCH
J9	12006	3 PRONG SOCKET	S3	303625	START SWITCH
J10	84244	9 PRONG SOCKET	S4	450149	SCAN SOLENOID SWITCH
J11	301020	4 PRONG SOCKET	S5	450150	CARRY-OVER SWITCH
J12	84293	4 PRONG SOCKET (Small)	S6	450255	CONTACT ASSEMBLY } Trigger
J13	201275	12 PRONG SOCKET	S6	450105	CONTACT SEGMENT Assy. } Switch
J14	303528	33 PRONG SOCKET	S7	450149	SCAN SOLENOID SWITCH
J15	303529	33 PRONG PLUG	S8	450150	CARRY-OVER SWITCH
J16	201275	12 PRONG SOCKET	S9	450272	CONTACT ASSEMBLY } Trfger
J17	301034	6 PRONG SOCKET (Small)	S9	450132	CONTACT SEGMENT Assy. } Switch
K1	303545	LETTER STEP RELAY	S10	450089	Rear Credit Wheel Switch Assembly
K2	303541	PAWL RESET MAGNET	S11	450140	Front Credit Wheel Switch Assembly
K3	303546	NUMBER STEP RELAY	T1	303680	POWER TRANSFORMER
K4	303077	PLAY CONTROL RELAY	T2	303569	25 V. TRANSFORMER
K5	303074	TRANSFER RELAY	T3	303457	PULSE TRANSFORMER
K6	303589	TIMING RELAY NO. 2		303455	PULSE TRANSFORMER (Alternate)
K7	303588	TIMING RELAY NO. 1	V1	308120	12AX7 VACUUM TUBE
K8	450100	SUBTRACT Two (2) SOLENOID	V2	308003	2050 THYRATRON
K9	450158	SUBTRACT Three (3) SOLENOID	V3	308626	6X4 VACUUM TUBE
K10	450162	ADD Six (6) SOLENOID	V4	308005	0A2 VOLTAGE REG. TUBE
K11	450152	ADD Two (2) SOLENOID	V5	308005	0A2 VOLTAGE REG. TUBE
K12	450154	ADD One (1) SOLENOID	V6	308003	2050 THYRATRON
K13	450280	TIMING RELAY	Z1	303590	PULSE AMPLIFIER ASSEMBLY
L1	303602	16 <i>ub</i> CHOKE ± 5%	Z2	303520	RELAY STEP SWITCH ASSEMBLY
L2	303602	16 <i>ub</i> CHOKE ± 5%	Z3	303510	STEP SWITCH ASSEMBLY
L3	303600	11 <i>ub</i> CHOKE ± 5%	Z4	450500	DUAL CREDIT UNIT, Type DCU1L-L6
L4	303600	11 <i>ub</i> CHOKE ± 5%	Z5	450078	CREDIT WHEEL ASSEMBLY
L5	303603	130 <i>ub</i> CHOKE ± 5%			

# TORMAT SELECTION RECEIVER, TYPE TSR3-L6

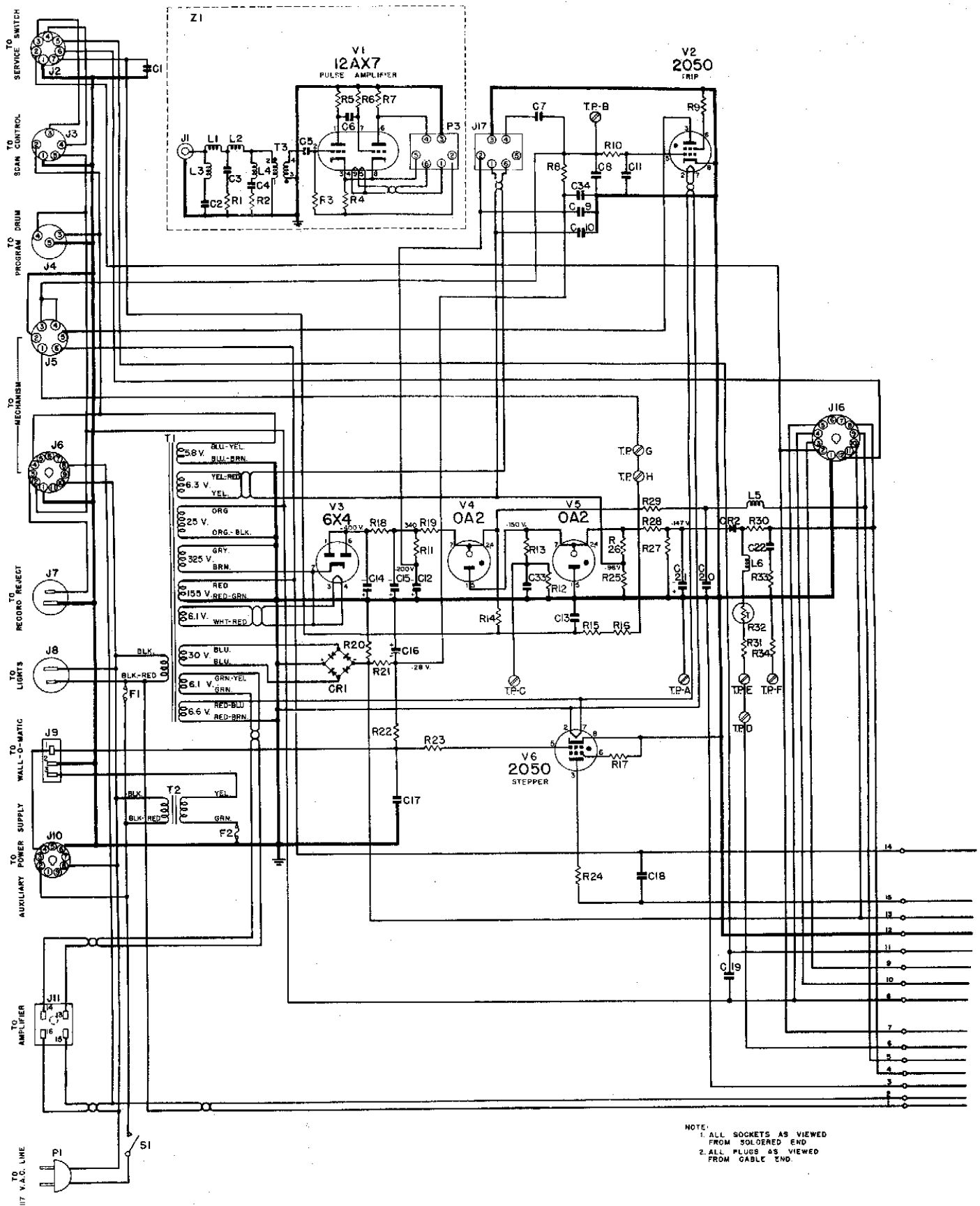

Schematic Diagram

# TORMAT SELECTION RECEIVER, TYPE TSR3-L6

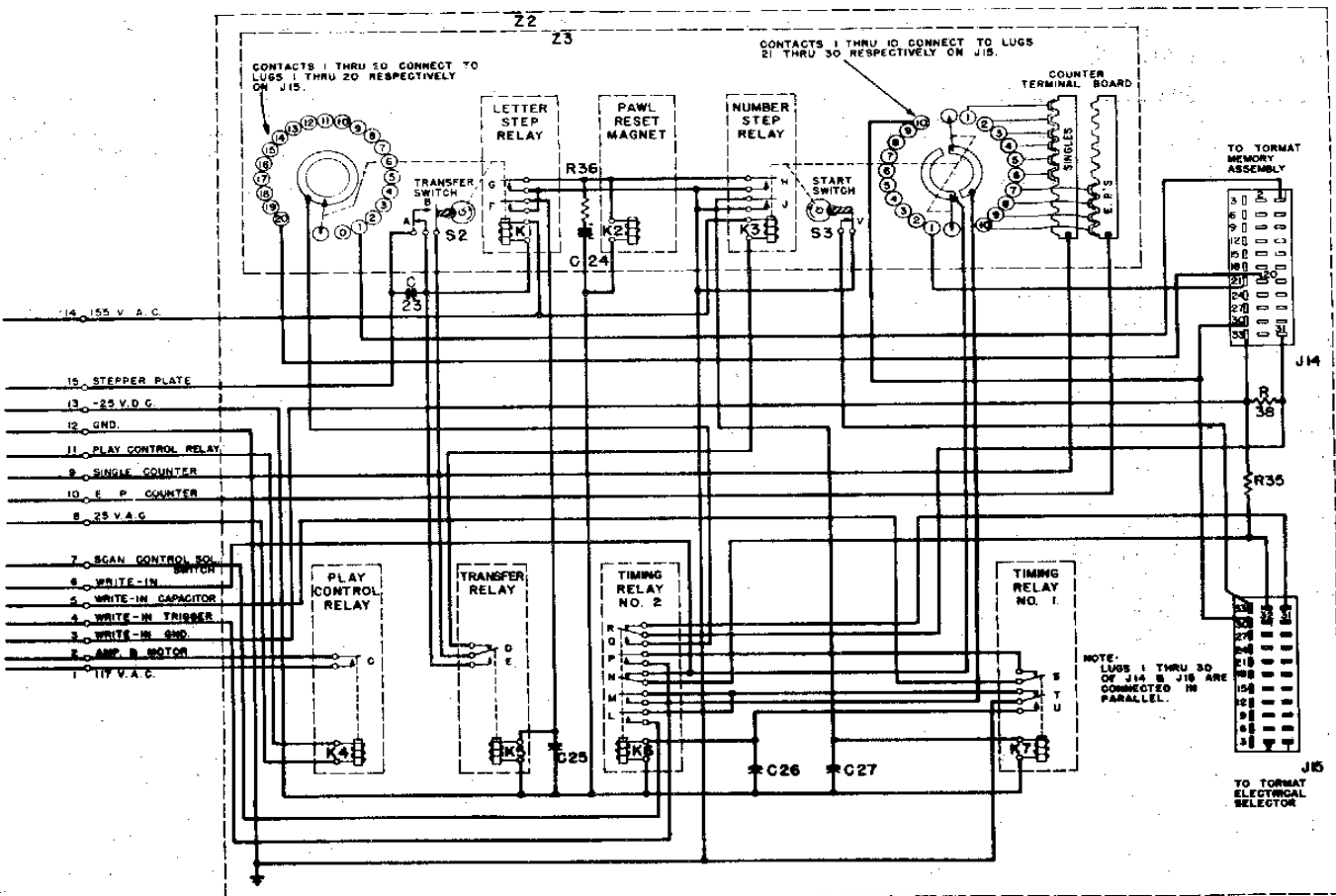
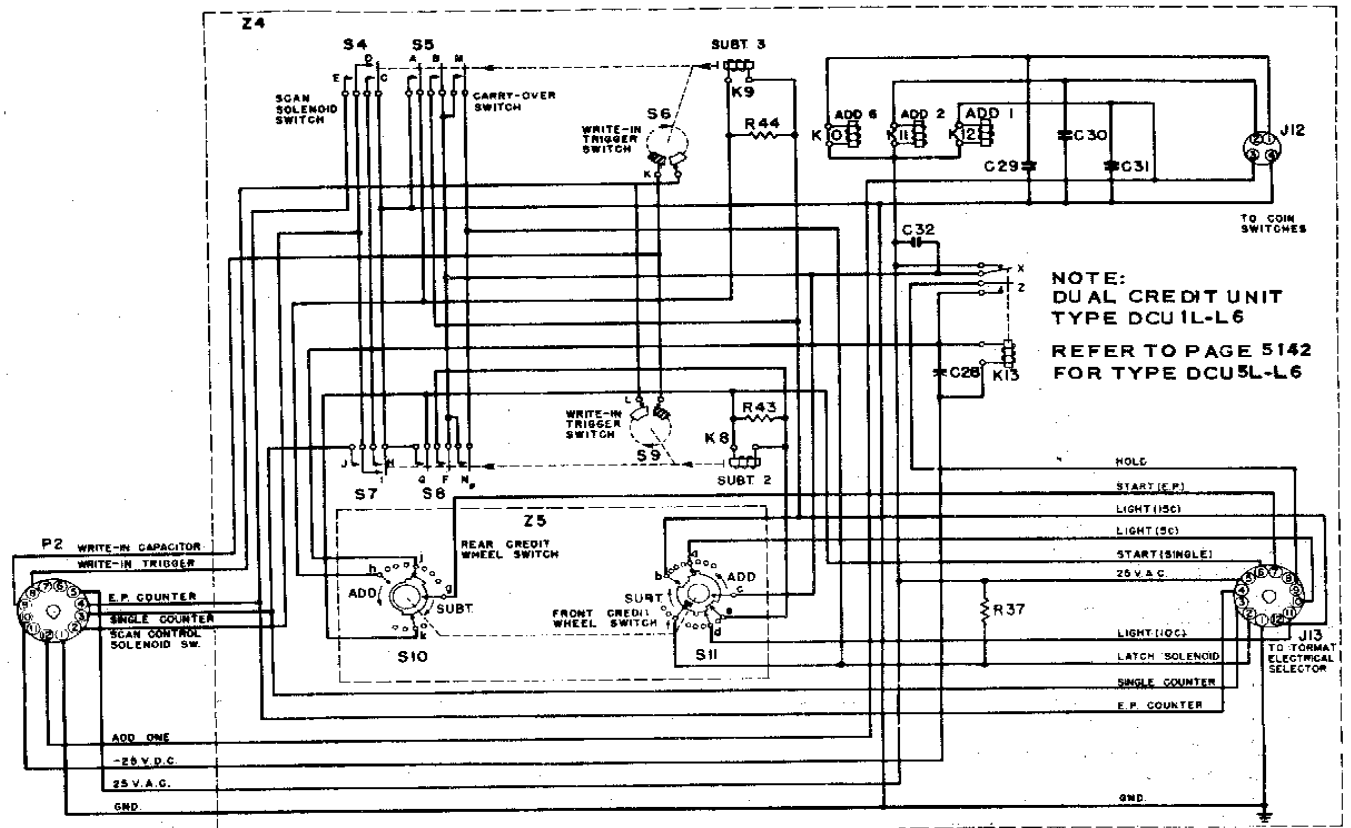

Schematic Diagram



TORMAT SELECTION RECEIVER, TYPE TSR3-L6

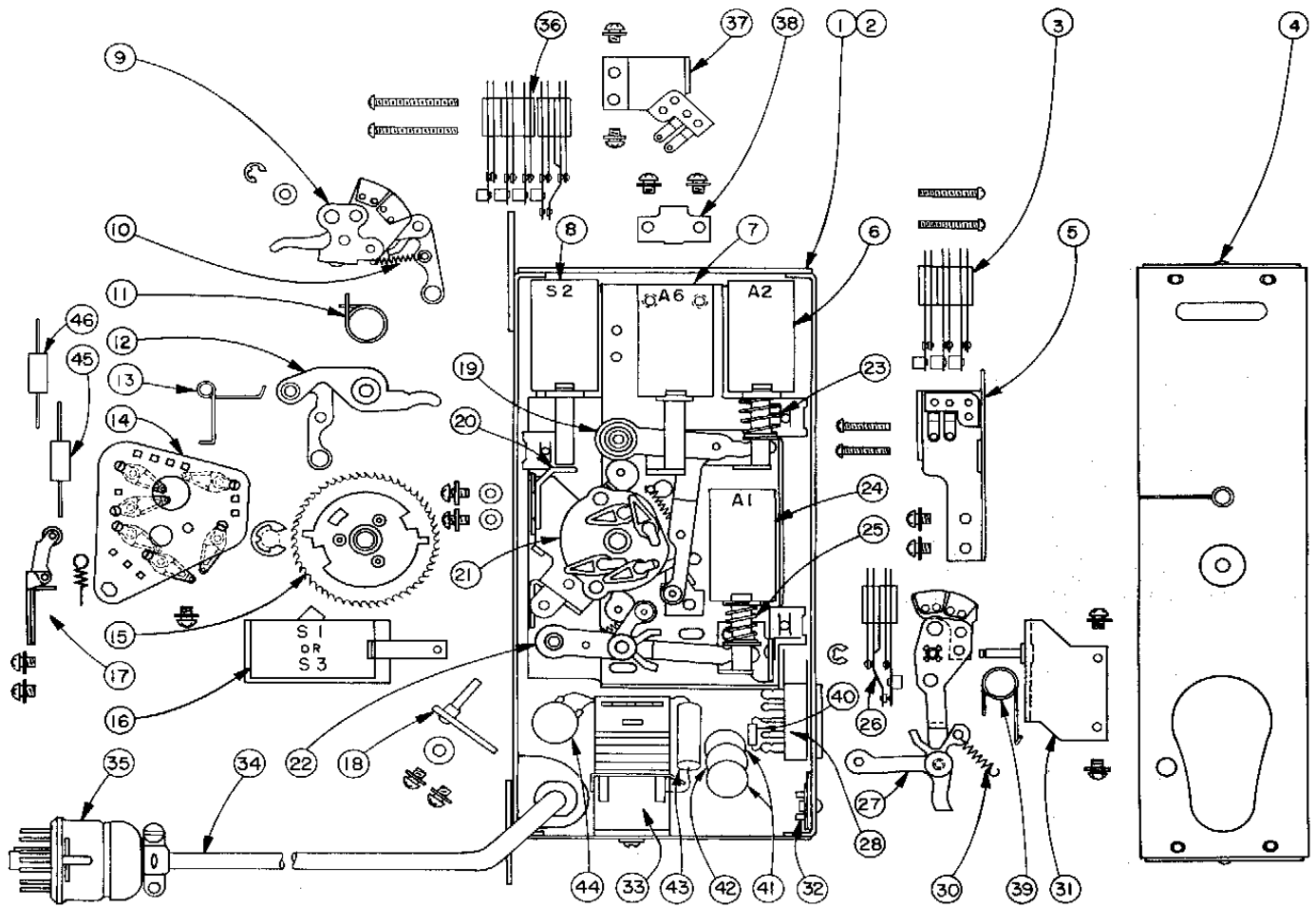

Dual Credit Unit Assemblies

PARTS LIST

Item	Part No.	Part Name	Item	Part No.	Part Name
1	* 450300	COMPLETE UNIT	19	920739	FLAT WASHER
2	† 450502	COMPLETE UNIT		912968	SEMS
3	* 450022	MOUNTING PLATE STAKED ASSEMBLY	20	450111	CREDIT ARM ASSEMBLY (ADD 2)
	450259	CARRY-OVER SWITCH		450129	SPRING
	450260	TAPPED PLATE		450102	PLUNGER STOP BRACKET (SUB 2)
4	† 450211	CARRY-OVER SWITCH	21	912859	SEMS
	450259	TENSION PLATE		450089	TERMINAL BOARD ASSEMBLY
	910991	3-48 X 5/8 PHILLIPS R.H.M.S.	22	450085	CREDIT ARM ASSEMBLY (ADD 1)
4	† 450247	COVER ASSEMBLY		450096	SPRING
	450297	COVER ASSEMBLY	23	450329	SPRING
5	† 450254	SWITCH MOUNTING BRACKET	24	450184	COIL & BRACKET ASSEMBLY (ADD 1)
		ASSEMBLY (SUB 3)		450075	SOLENOID PLUNGER ASSEMBLY
	† 450344	SWITCH MOUNTING BRACKET ASSEMBLY (SUB 1)	25	450325	SPRING
	912882	SEMS	26	* 450149	SWITCH
6	450182	COIL & BRACKET ASSEMBLY (ADD 2)	† 450210	SWITCH	
	450075	SOLENOID PLUNGER ASSEMBLY		450259	TAPPED PLATE
	912882	SEMS		450260	TENSION PLATE
7	450186	CREDIT COIL & BRACKET ASSEMBLY (ADD 6)		911011	3-48 X 1/4 PHILLIPS R.H.M.S.
	450074	SOLENOID PLUNGER ASSEMBLY	27	* 450105	CANCEL ARM ASSEMBLY (SUB 3)
	912882	SEMS	† 450339	CANCEL ARM ASSEMBLY (SUB 1)	
8	450190	CANCEL COIL & BRACKET ASSEMBLY (SUB 2)	28	84301	12 PRONG SOCKET
	450075	SOLENOID PLUNGER ASSEMBLY	30	450129	SPRING
	912882	SEMS	31	* 450037	PIVOT BRACKET ASSEMBLY
9	450132	CANCEL ARM ASSEMBLY (SUB 2)	† 450332	PIVOT BRACKET ASSEMBLY	
	125448	RETAINING RING		912882	SEMS
	921112	WASHER	32	84293	4 PRONG SOCKET
10	450096	SPRING	33	450280	TIMING RELAY
11	450130	TORSION SPRING		914225	SEMS
12	450121	CREDIT ARM ASSEMBLY (ADD 6)	34	450560	CABLE ASSEMBLY
13	450131	SPRING - TORSION	35	410707	12 PRONG PLUG ASSEMBLY
			36	450150	SWITCH (CARRY-OVER)
14	* 450140	CONTACT PLATE ASSEMBLY		450149	SWITCH
	† 450342	CONTACT PLATE ASSEMBLY		911073	3-48 X 1/4 PHILLIPS R.H.M.S.
	912859	SEMS	37	450261	SWITCH MOUNTING BRACKET ASSEMBLY (SUB 2)
15	450075	CREDIT WHEEL ASSEMBLY		912882	SEMS
	125403	RETAINING RING		450318	RESIDUAL SPRING
16	* 450188	COIL & BRACKET ASSEMBLY (SUB 3)		450317	RESIDUAL PIN
	† 450336	CANCEL COIL & BRACKET ASSEMBLY (SUB 1)		925342	FLAT WASHER
	912882	SEMS	39	450281	TORSION SPRING
	450075	SOLENOID PLUNGER ASSEMBLY	40	82707	1200 OHM 1 W RESISTOR
	† 450348	SOLENOID PLUNGER ASSEMBLY	41	86259	.02 CERAMIC CONDENSER
17	450465	DETENT ROLLER ASSEMBLY	42	86258	.04 CERAMIC CONDENSER
	450464	DETENT SPRING ONLY	43	86142	.1 MFD. 200 V CONDENSER
	910821	3-48 X 3/16 PHILLIPS R.H.M.S.	44	86259	.02 MFD. CERAMIC CONDENSER
18	450326	STOP PIN PLATE ASSEMBLY	45	82638	100 OHM 2 W. RESISTOR

\* USED ON TYPE DCU1L-L6

† USED ON TYPE DCU5L-L6

*Seeburg*

## TORMAT SELECTION RECEIVER TYPE TSR4-L6

The Tormat Selection Receiver, Type TSR4-L6, is the power distribution and control center of the Select-O-Matic "200" R. C. Special, Model HVL-200 for operation from wired Wall-O-Matics, Type V-3WA. Power enters the Receiver through the line cord and main switch and is distributed, directly at 117-volts or through transformers, to the Select-O-Matic Mechanism, the cabinet lighting, the amplifier, and the Wall-O-Matics. All connections to the Receiver are made with plugs which are of different types and sizes to avoid possibility of incorrect connections. Included in the Receiver are a Step Switch and Relay Assembly, and a 2050 tube, for selection of records from Wired Wall-O-Matics.

A 25-volt transformer supplies power for up to six Type V-3WA Wall-O-Matics. Another transformer, the selection receiver power transformer, has seven output windings for control circuits, and heater current for the tubes in the High Fidelity Master Amplifier.

One of the secondaries of the selection receiver power transformer provides approximately 30-volts, a.c. This 30-volt output is rectified by a full-wave selenium rectifier for 25-volt d.c. supply for some of the relays of the Step Switch and Relay Assembly, and for bias supply for the 2050 tubes. Another secondary provides approximately 150 volts for operating the step switches through the plate circuit of a 2050 tube.

Operation of Selection Receiver, Type TSR4-L6, is the same as that of the Type TSR3-L6. All service notes, schematic diagrams, and parts lists applying to the Type TSR3-L6 apply to the Type TSR4-L6 except that there is no Dual Credit Unit incorporated for operation of an electrical selector. The space on the chassis of the TSR4-L6 is used for a Selection Counter Assembly, Part No. 303656. The parts list for this assembly is given below.

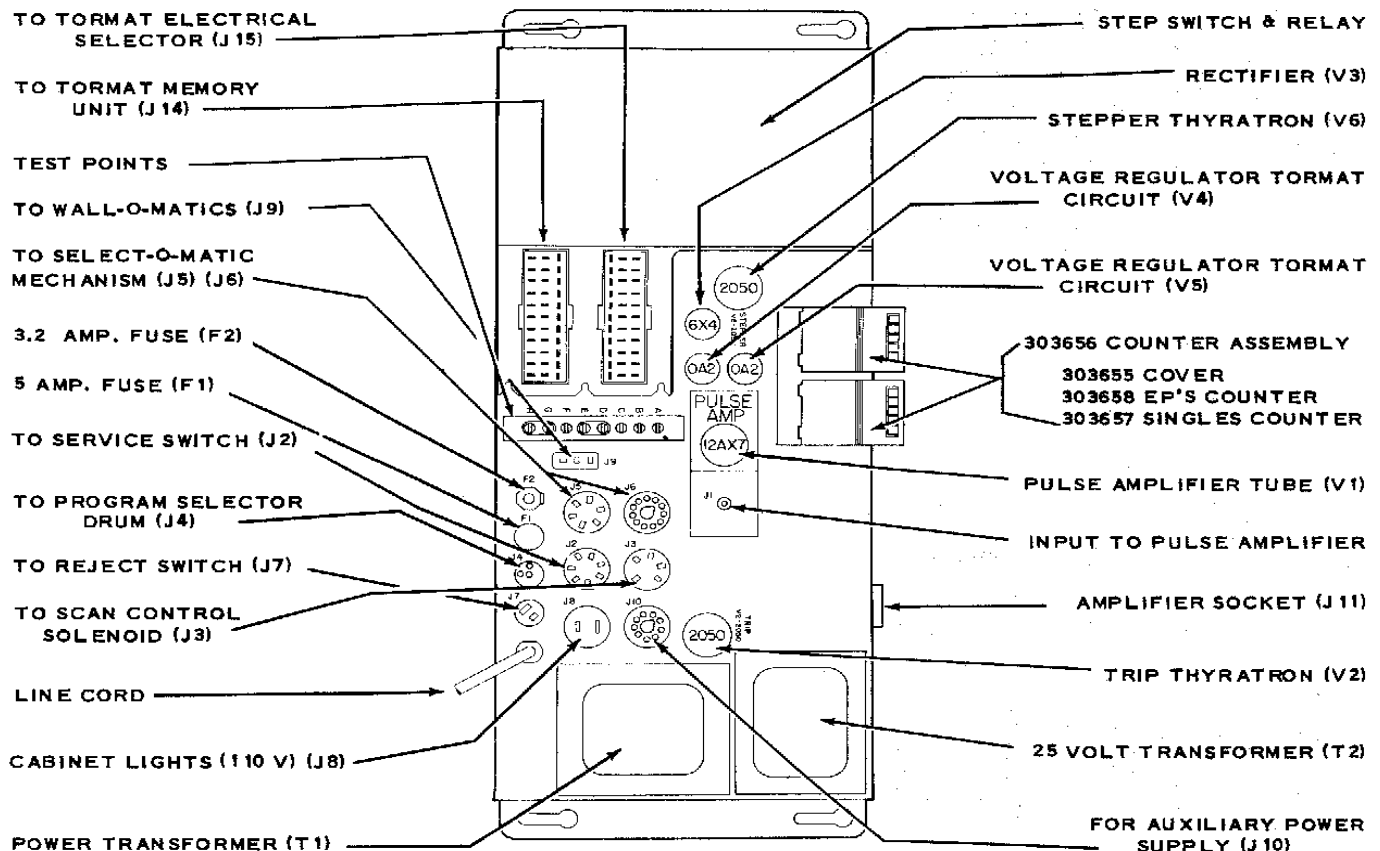

Figure 1.



**TORMAT SELECTION RECEIVER  
TYPE TSR3 - CODE B  
TYPE TSR4 - CODE B**

The Tormat Selection Receivers, Types TSR3 and TSR4, Code B, are interchangeable with and similar in most respects to, respectively, the Types TSR3 and TSR4 having code designation "A" or no code letter. The principle difference is in the connections provided for remote record reject and for the 3-wire cable for connection of Wall-O-Matics. The code B

receivers are equipped with screw terminals for these connections. Additional test points have been added for convenience in testing the selection system write-in circuits.

The location of the major components is shown below. The diagram on the following page details the circuit.

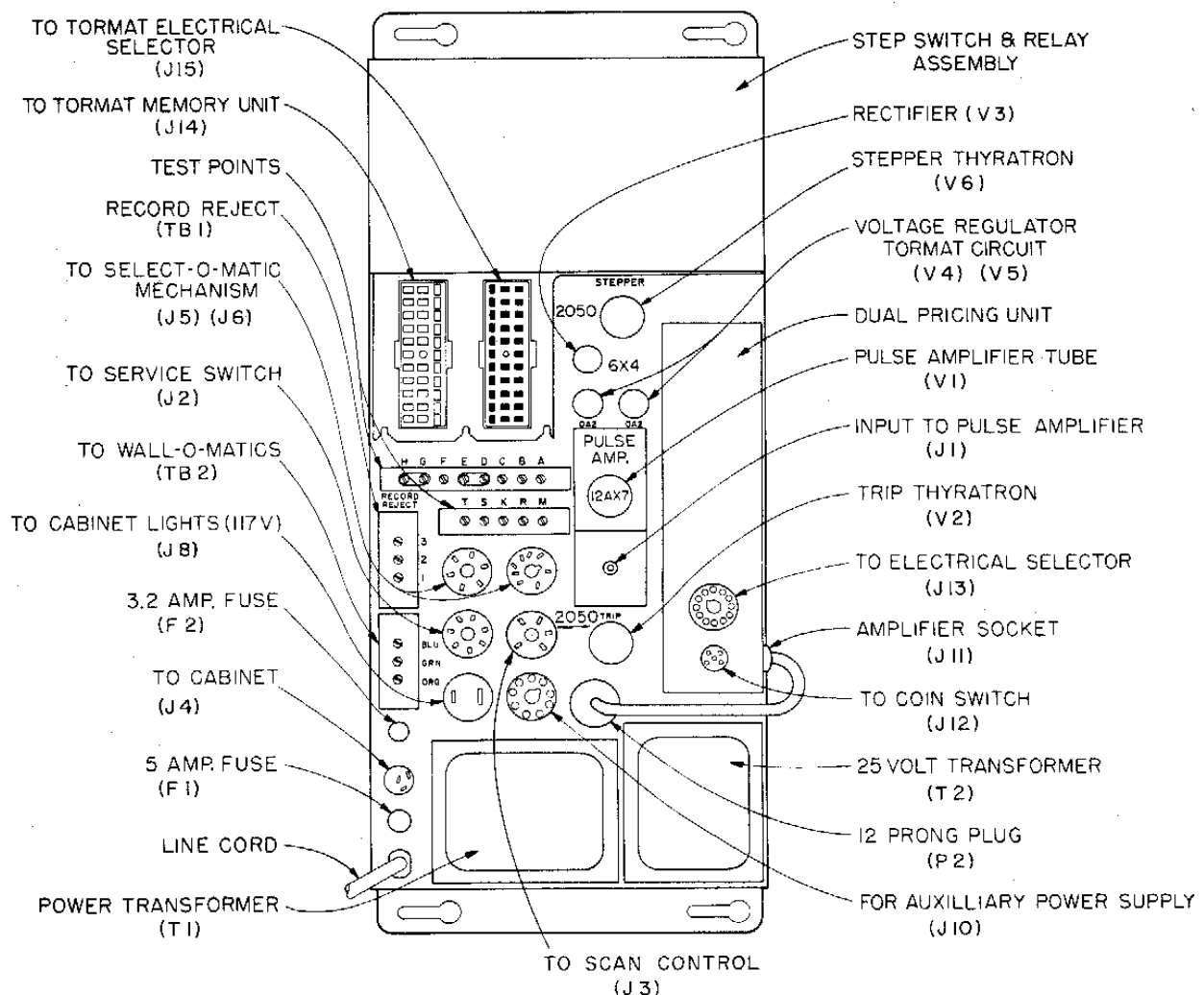
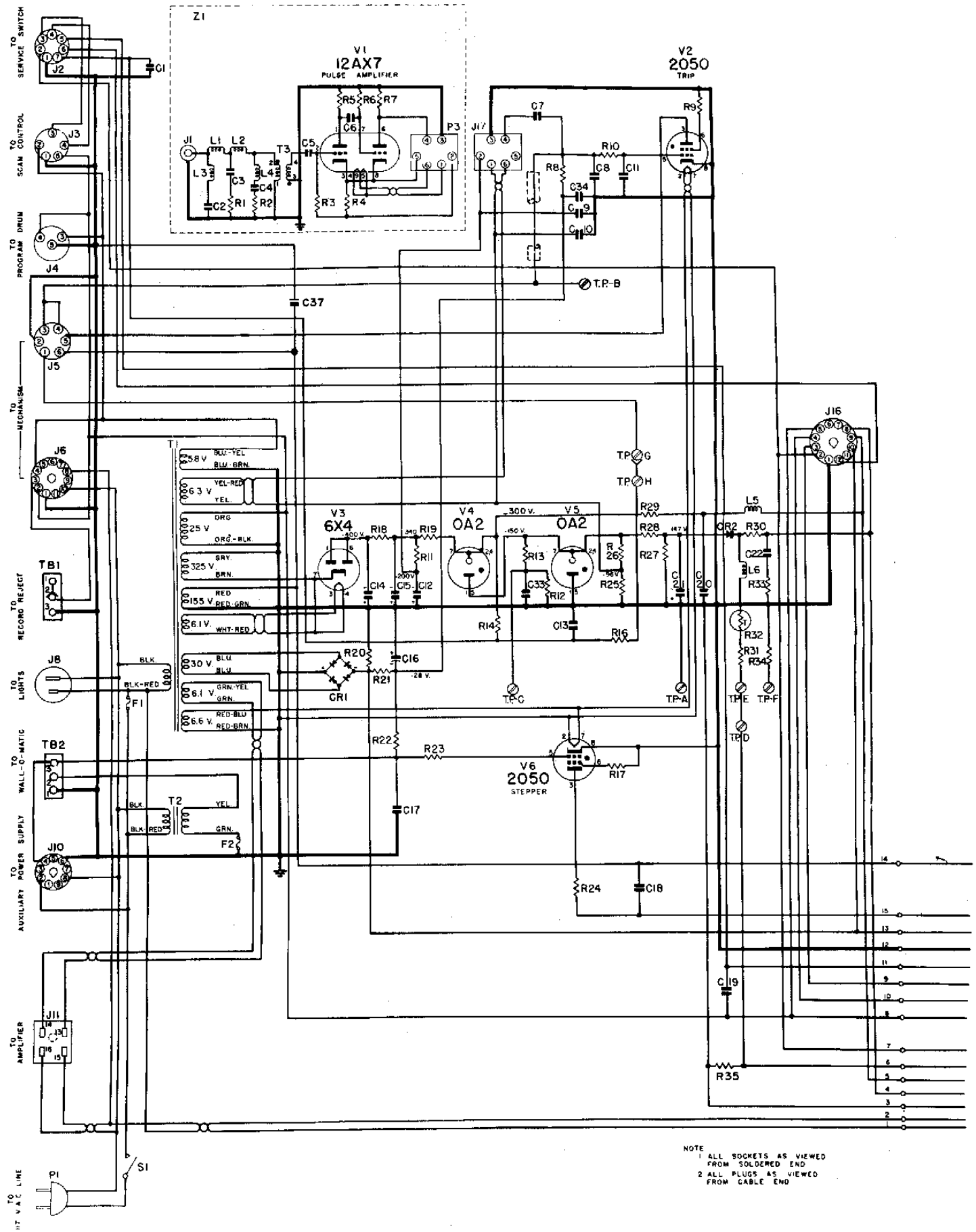

Figure 1.

# TORMAT SELECTION RECEIVER, TYPE TSR3 (4) CODE B



NOTE  
 1 ALL SOCKETS AS VIEWED FROM SOLDERED END  
 2 ALL PLUGS AS VIEWED FROM CABLE END

TORMAT SELECTION RECEIVER, TYPE TSR3 (4) CODE B

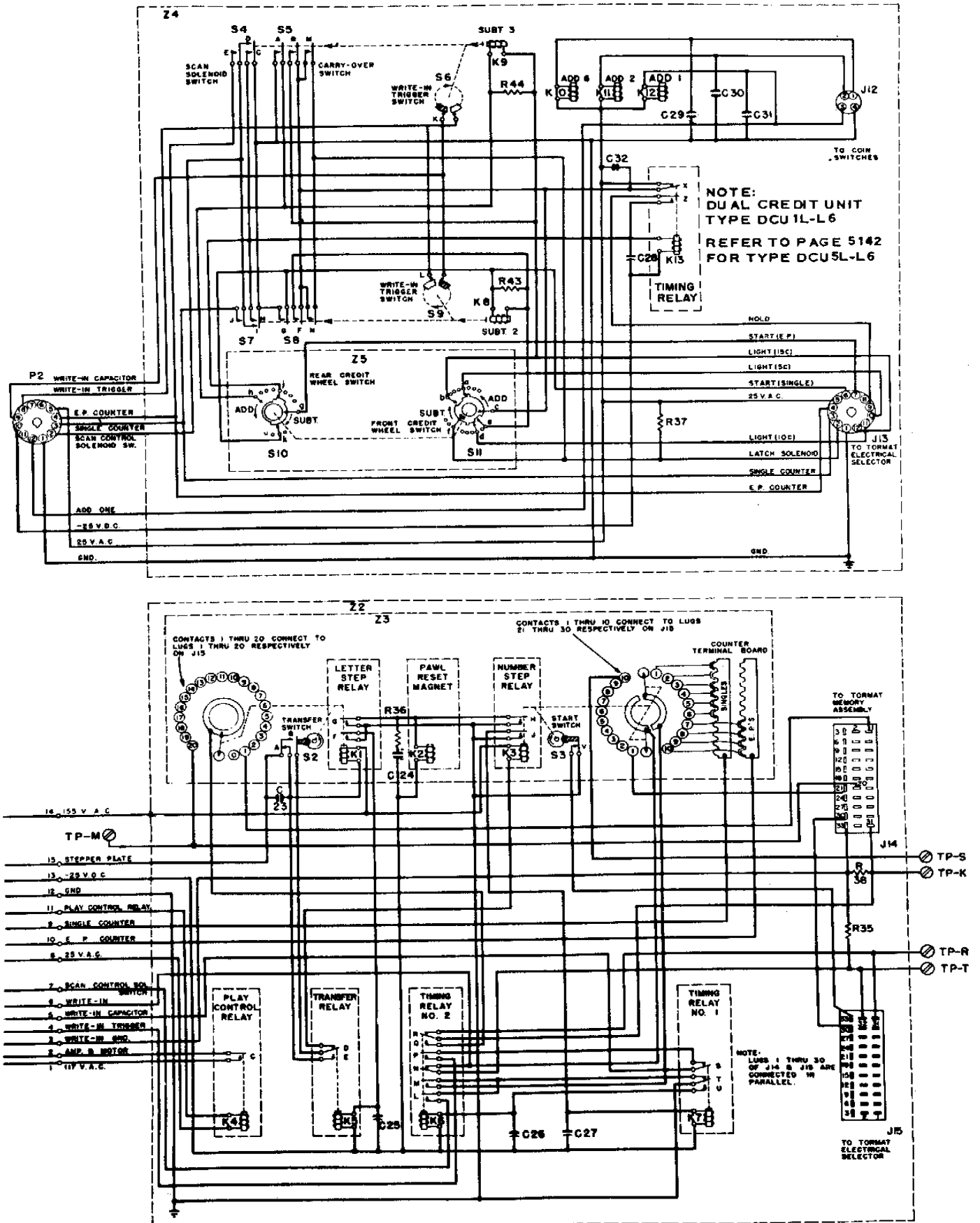

Schematic Diagram

TORMAT SELECTION RECEIVER, TYPE TSR3 (4) CODE B

**PARTS LIST**  
(For Pages 5148 and 5149)

Item	Part No.	Part Name	Item	Part No.	Part Name
C1	86251	3000 MMF 500 V. CERAMIC	P2	410707	12 PRONG PLUG
C2	86253	360 MMF ± 10% 500 V. CERAMIC	P3	303599	6 PRONG PLUG
C3	86252	1200 MMF ± 10% 500 V. CERAMIC	R1	82409	56 OHM ± 10% ½ W.
C4	86253	360 MMF ± 10% 500 V. CERAMIC	R2	82409	56 OHM ± 10% ½ W.
C5	86251	3000 MMF 500 V. CERAMIC	R3	82444	47,000 OHM ± 10% ½ W.
C6	86030	.05 MFD ± 10% 400 V. PAPER	R4	82610	6200 OHM ± 5% ½ W.
C7	86248	.15 MFD ± 10% 200 V. PAPER	R5	82456	470,000 OHM ± 10% ½ W.
C8	86235	.05 MFD 200 V. PAPER	R6	82469	5.6 MEGOHM ± 10% ½ W.
C9	86251	3000 MMF 500 V. CERAMIC	R7	82640	27,000 OHM ± 5% ½ W.
C10	86313	.01 MFD 500 V. CERAMIC	R8	82460	1.0 MEGOHM ± 10% ½ W.
C11	86255	2000 MMF 500 V. CERAMIC	R9	82440	22,000 OHM ± 10% ½ W.
C12	87637	10 MFD 450 V. LYTIC	R10	82456	470,000 OHM ± 10% ½ W.
C13	86296	.15 MFD ± 10% 600 V. PAPER	R11	82695	56,000 OHM ± 5% ½ W.
C14	87635	15 MFD 450 V. LYTIC	R12	82449	120,000 OHM ± 10% ½ W.
C15	87635	15 MFD 450 V. LYTIC	R13	82464	2.2 MEGOHM ± 10% ½ W.
C16	87571	25 MFD 50 V. LYTIC	R14	82815	100,000 OHM ± 10% 2 W.
C17	86235	.05 MFD 200 V. PAPER	R16	82993	36 OHM ± 5% ½ W.
C18	11076	5 MFD 300 V. PAPER	R17	82440	22,000 OHM ± 10% ½ W.
C19	86142	.1 MFD 200 V. PAPER	R18	81190	3,300 OHM ± 10% W.W. 5 W.
C20	86295	.068 MFD ± 10% 600 V. PAPER	R19	82836	2,700 OHM ± 10% 2 W.
C21	87636	10 MFD 150 V. LYTIC	R20	82432	4,700 OHM ± 10% ½ W.
C22	86313	.01 MFD 500 V. CERAMIC	R21	82456	470,000 OHM ± 10% ½ W.
C23	86250	5000 MMF 1000 V. CERAMIC	R22	82448	100,000 OHM ± 10% ½ W.
C24	87611	300 MFD 50 V. LYTIC	R23	82436	10,000 OHM ± 10% ½ W.
C25	86235	.05 MFD 200 V. PAPER	R24	82838	100 OHM ± 10% 2 W.
C26	86235	.05 MFD 200 V. PAPER	R25	82454	330,000 OHM ± 10% ½ W.
C27	86235	.05 MFD 200 V. PAPER	R26	82451	180,000 OHM ± 10% ½ W.
C28	86142	.1 MFD 200 V. PAPER	R27	82698	150,000 OHM ± 5% ½ W.
C29	86258	.04 MFD 500 V. CERAMIC	R28	82611	3000 OHM ± 5% ½ W.
C30	86259	.02 MFD 500 V. CERAMIC	R29	82992	120,000 OHM ± 10% 1 W.
C31	86258	.04 MFD 500 V. CERAMIC	R30	82617	47 OHM ± 5% ½ W.
C32	86259	.02 MFD 500 V. CERAMIC	R32	303694	Positive Temp. Coeff. Resistor
C33	86252	1200 MMF ± 10% 500 V. CERAMIC	R33	82617	47 OHM ± 5% ½ W.
C34	86251	3000 MMF 500 V. CERAMIC	R34	82437	12,000 OHM ± 10% ½ W.
C37	86154	.02 MFD 600 V. PAPER	R35	82439	18,000 OHM ± 10% ½ W.
CR1	400587	SELENIUM RECTIFIER	R36	82403	18 OHM ± 10% ½ W.
CR2	303696	IN368 GERMANIUM DIODE	R37	82707	1200 OHM ± 10% 1 W.
F1	602411	5 AMP. FUSE, TYPE MTH	R38	82439	18,000 OHM ± 10% ½ W.
F2	303697	3.2 AMP. FUSE TYPE N3-2/10	R43	82838	100 OHM ± 10% 2 W.
J1	300152	SINGLE PRONG SOCKET	R44	82838	100 OHM ± 10% 2 W.
J2	84282	7 PRONG SOCKET	S1	303112	TOGGLE SWITCH, S.P.S.T.
J3	84283	5 PRONG SOCKET	S2	303547	TRANSFER SWITCH
J4	303555	3 PRONG MIN. SOCKET	S3	303625	START SWITCH
J5	84223	6 PRONG SOCKET	S4	450149	SCAN SOLENOID SWITCH
J6	303253	11 PRONG SOCKET	S5	450150	CARRY-OVER SWITCH
J8	11401	2 PRONG SOCKET	S6	450255	CONTACT ASSEMBLY
J10	84244	9 PRONG SOCKET	S6	450105	CONTACT SEGMENT Assy. } Trigger Switch
J11	301020	4 PRONG SOCKET	S7	450149	SCAN SOLENOID SWITCH
J12	84293	4 PRONG SOCKET (Small)	S8	450150	CARRY-OVER SWITCH
J13	201275	12 PRONG SOCKET	S9	450272	CONTACT ASSEMBLY
J14	303528	33 PRONG SOCKET	S9	450132	CONTACT SEGMENT Assy. } Trigger Switch
J15	303529	33 PRONG PLUG	S10	450089	Rear Credit Wheel Switch Assembly
J16	201275	12 PRONG SOCKET	S11	450140	Front Credit Wheel Switch Assembly
J17	301034	6 PRONG SOCKET (Small)	T1	303680	POWER TRANSFORMER
K1	303545	LETTER STEP RELAY	T2	309210	25 V. TRANSFORMER
K2	303541	PAWL RESET MAGNET	T3	303457	PULSE TRANSFORMER
K3	303546	NUMBER STEP RELAY	TB1	305447	TERMINAL BOARD
K4	303077	PLAY CONTROL RELAY	TB2	305309	TERMINAL BOARD
K5	303074	TRANSFER RELAY	V1	308120	12AX7 VACUUM TUBE
K6	303589	TIMING RELAY NO. 2	V2	308003	2050 THYRATRON
K7	303588	TIMING RELAY NO. 1	V3	308626	6X4 VACUUM TUBE
K8	450100	SUBTRACT Two (2) SOLENOID	V4	308005	0A2 VOLTAGE REG. TUBE
K9	450158	SUBTRACT Three (3) SOLENOID	V5	308005	0A2 VOLTAGE REG. TUBE
K10	450162	ADD Six (6) SOLENOID	V6	308003	2050 THYRATRON
K11	450152	ADD Two (2) SOLENOID	Z1	303590	PULSE AMPLIFIER ASSEMBLY
K12	450154	ADD One (1) SOLENOID	Z2	303520	RELAY STEP SWITCH ASSEMBLY
K13	450280	TIMING RELAY	Z3	303510	STEP SWITCH ASSEMBLY
L1	303602	16 <i>ub</i> CHOKE ± 5%	Z4	450500	DUAL CREDIT UNIT, Type DCU1L-L6
L2	303602	16 <i>ub</i> CHOKE ± 5%		450502	DUAL CREDIT UNIT, Type DCU5L-L6
L3	303600	11 <i>ub</i> CHOKE ± 5%		450504	DUAL CREDIT UNIT, Type DCU6L-L6
L4	303600	11 <i>ub</i> CHOKE ± 5%		450506	DUAL CREDIT UNIT, Type DCU7L-L6
L5	303603	130 <i>ub</i> CHOKE ± 5%			
L6	303601	27 <i>ub</i> CHOKE ± 5%			
P1	303985	LINE CORD & PLUG ASSEMBLY	Z5	450078	CREDIT WHEEL ASSEMBLY