

# **SEEBURG**

**TORMAT ELECTRICAL SELECTOR**

**TYPE TES163**

# SEEBURG

## TORMAT ELECTRICAL SELECTOR, Type TES163

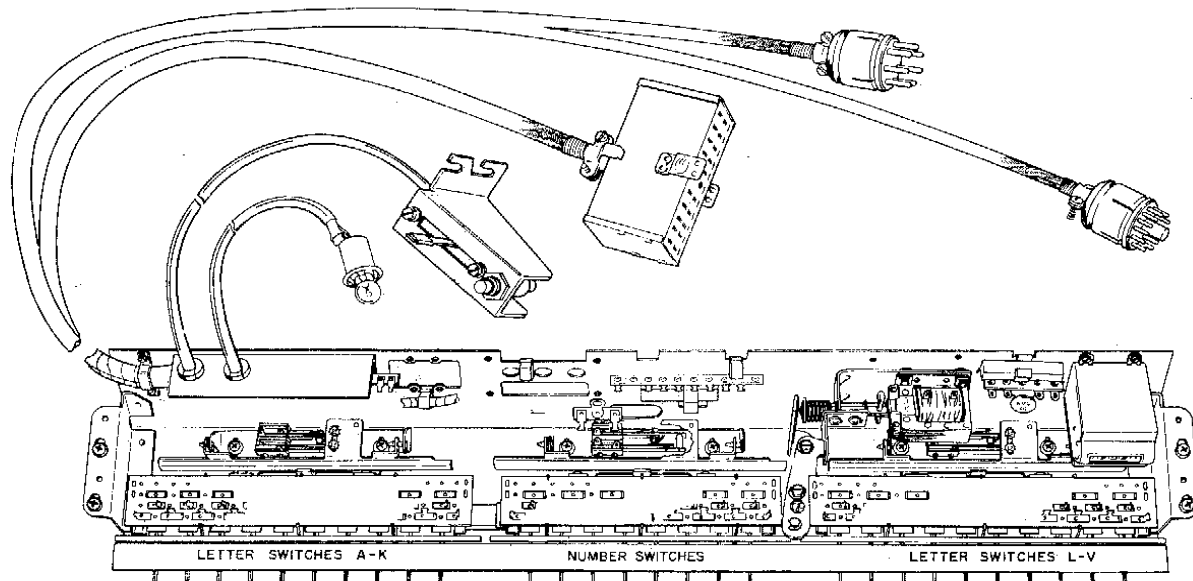

The Tormat Electrical Selector, Type TES163 is part of the Seeburg Tormat Selection System. The principal functions of the Selector is to connect a letter and a number circuit of the Tormat Memory Unit into a selection write-in circuit and to complete a circuit that initiates the operational sequence of the system. These functions are performed when two of the selection switches are operated by pressing a lettered selector key and a numbered key.

The principal parts of the Selector include the service switch, three selection switch assemblies, a latch bar operating solenoid, credit indicating light and three switch groups each of which has two pairs of contacts. There is also a counter which totals the number of selections made with remote control Wall-O-Matics as well as those made with the Electrical Selector.

The credit indicating light is extended on its connecting leads so it illuminates the selection information window that is in the cabinet frame casting at the left of the selector key panel. It is a 6-volt lamp operated at 25 volts through a 65-ohm resistor.

The latch bar function is to hold a selection switch (and selector key) in the pressed-in position when a selection is being made and to release it when the selection operation sequence is completed. The bars in the two letter switch assemblies are coupled end-to-end so they operate as a single continuous bar. The

latch bar of the number switch is independent of the letter switches but the bars in both letter and number switches are linked to and controlled by the latch bar solenoid. The linkage between the solenoid and the bars is spring biased so the bar position permits free in and out movement of the selection switches when the solenoid is not energized. When the solenoid is energized, the bars move to a position in which they will hold a pressed-in switch in the operated position however, the bars are designed so a latched-in switch will be released if another switch in same number or letter switch group is pressed in. The solenoid is energized when credits are set up in the phonograph.

The shafts or stems of the selector switches extend through the switch frame. They operate a treadle bar when a selector key is pressed and the treadle bar, in turn, operates a switch group consisting of a spring-leaf switch and a snap-action, over-center switch. One of the three switch groups is associated with each of the three selection switches and operates when a selector key is pressed. The three spring-leaf switches in the two switch groups are parallel connected and are part of a timing relay holding circuit that is completed through interlocking contacts on the relay when any one of the selector keys is pressed. These switches are the Hold Switches, contacts U, X and W.

The snap-action switches are the Starting Switches, contacts V, Y and Z. The Y and Z contacts are operated by the Letter Selection switches and are parallel connected so one or the other

## TORMAT ELECTRICAL SELECTOR, TYPE TES 163

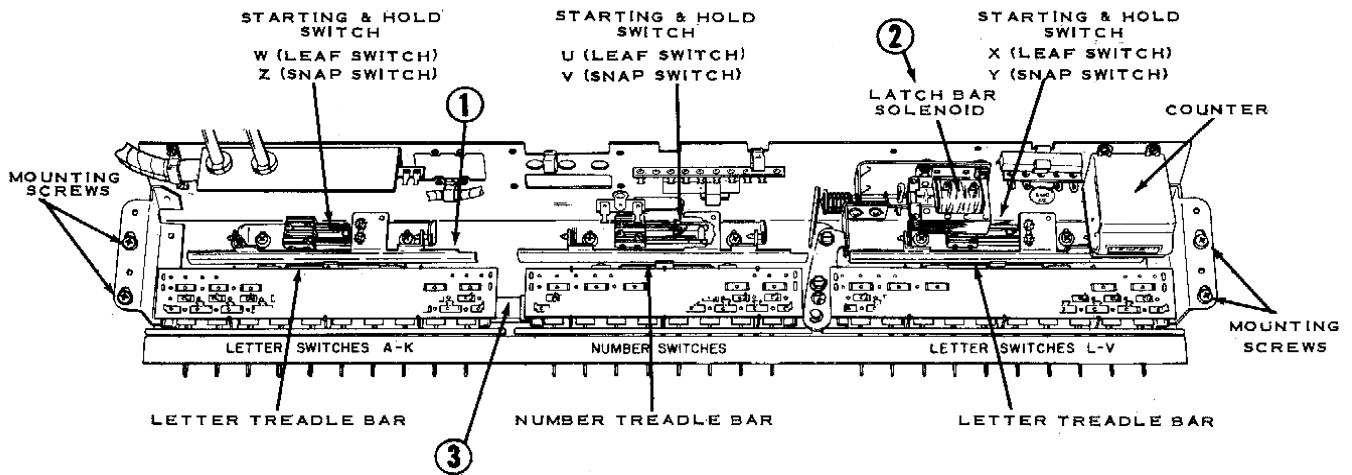

closes whenever a Letter selector key is pressed. The Z contact is closed by pressing any Number selector key and is in series with the parallel-connected Y and Z contacts. These contacts are part of a circuit that includes a Subtract Solenoid or a Cancel Solenoid. When a letter key and a number key are pressed, the starting switches complete the circuit to the solenoid which, when energized, closes switch contacts that control the power to the Tormat Memory Unit, the selection counter and the timing relay. They also close, momentarily, the circuit for a play control add solenoid that, in turn, controls, through a play control unit, the power to the phonograph amplifier and the mechanism motor.

### REMOVAL OF SELECTOR

All adjustments of the mechanical linkage except Adjustment No. 2, all switch adjustments and all circuits of the Selector are accessible for inspection and service without removing it from the cabinet. The entire unit may be removed for any service and for Adjustment No. 2 by pulling out the connecting plugs at the ends of the

cable and taking out the screws that are back of the selector key panel at each end of the Selector frame.

When replacing the Selector in the cabinet it should be fastened securely with the mounting screws. It should be positioned so there is a minimum of clearance between the ends of the selection switch shafts and the back of the selector keys. If, however, it is too far toward the keys the selection switches may not return far enough to the released position to open the timing relay circuit that is operated by the Hold Switches. If it is too far from the keys, the keys will be loose and may settle.

### LUBRICATION

Oil all pivots with one drop of Seeburg No. 53014 Select-O-Matic Special Purpose Oil. Use Aero Lubriplate sparingly on the surfaces of the latch levers where they bear on solenoid plunger and the latch bars. (*Aero Lubriplate and No. 53014 Oil is available from your Seeburg Distributor.*)

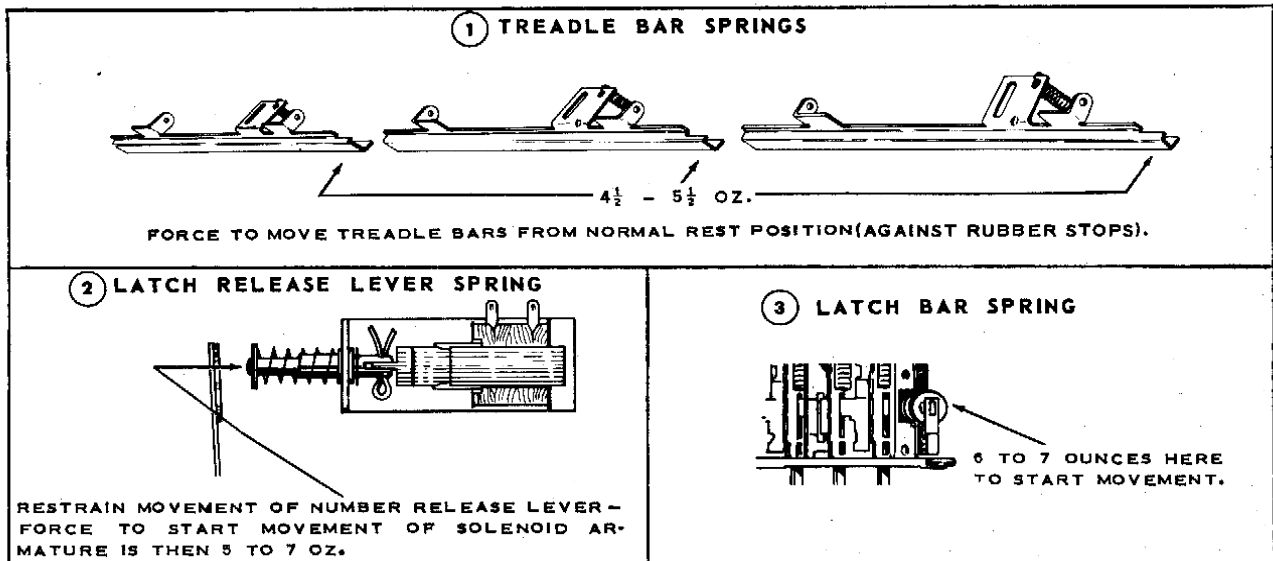

# TORMAT ELECTRICAL SELECTOR, Type TES163

## ADJUSTMENT NO. 1 - LETTER SWITCH L-V

This adjustment positions the latch bar in the L-V LETTER selector switch so that when credits are established, the selector switches will latch in the pressed-in position but permit change of selection by operating another switch in the L-V group.

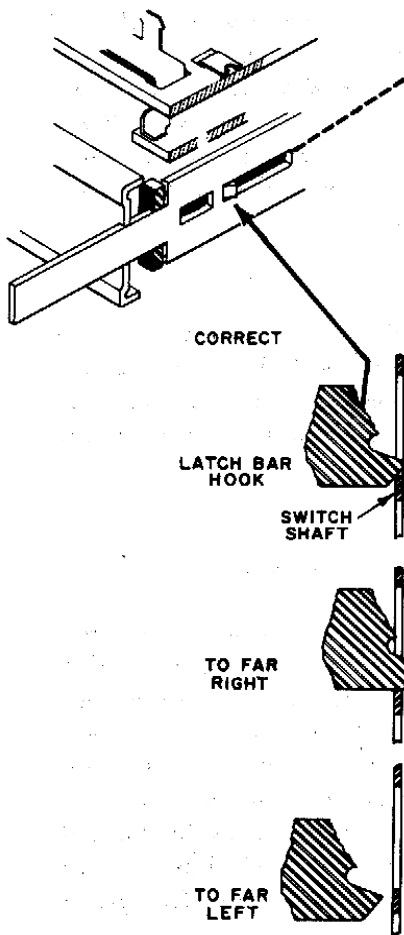
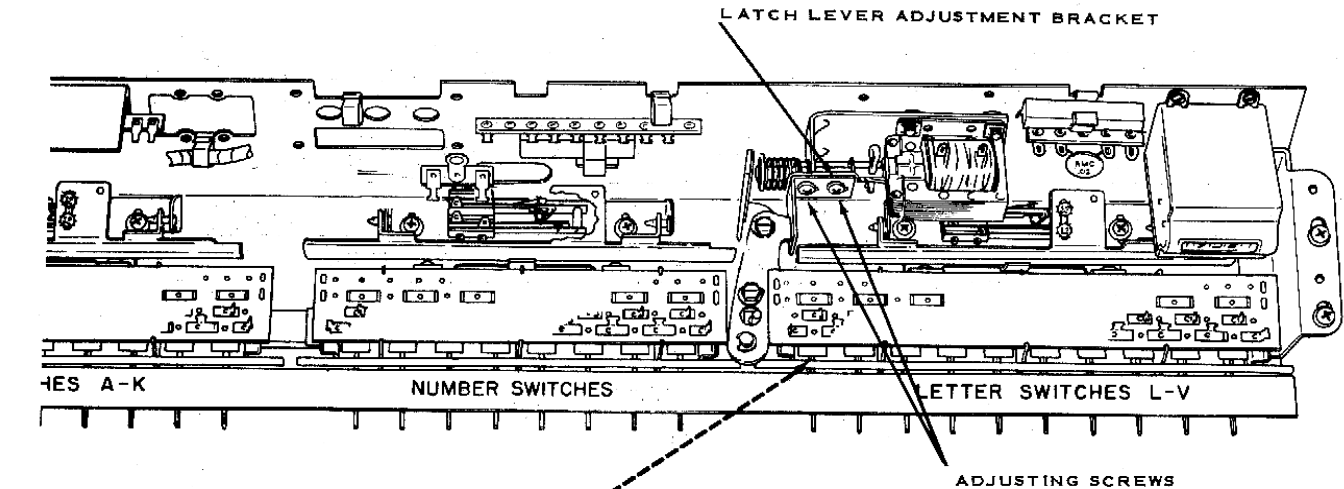

*NOTE: When making this adjustment the latch bar solenoid must be in the energized position, all linkage and bars must be free to move without binding and there should be a gap between the latch release lever and the end of the latch bar solenoid plunger rod.*

**A** Loosen the two screws holding the latch lever adjustment bracket and position the bracket so the tips of the latch bar hooks extend  $1/64$  inch through the openings in the selector switch shafts. The bars and shafts may be seen through openings in the bottom of the Selector frame.

**B** If the bracket is too far to the right, the selector keys will be locked out. If the bracket is too far to the left, the selector keys will not latch or the latching will be erratic.

**C** After the correct position of the bracket has been made, the bracket holding screws must be securely tightened.

TORMAT ELECTRICAL SELECTOR, Type TES163

ADJUSTMENT NO. 2 - LETTER SWITCH A-K

This adjustment positions the latch bar of the A-K LETTER SWITCH so these lettered selector switches will operate in the same manner provided for the L-V LETTER SWITCH in Adjustment No. 1. The adjusting link is accessible through a hole in the bottom of the Selector frame.

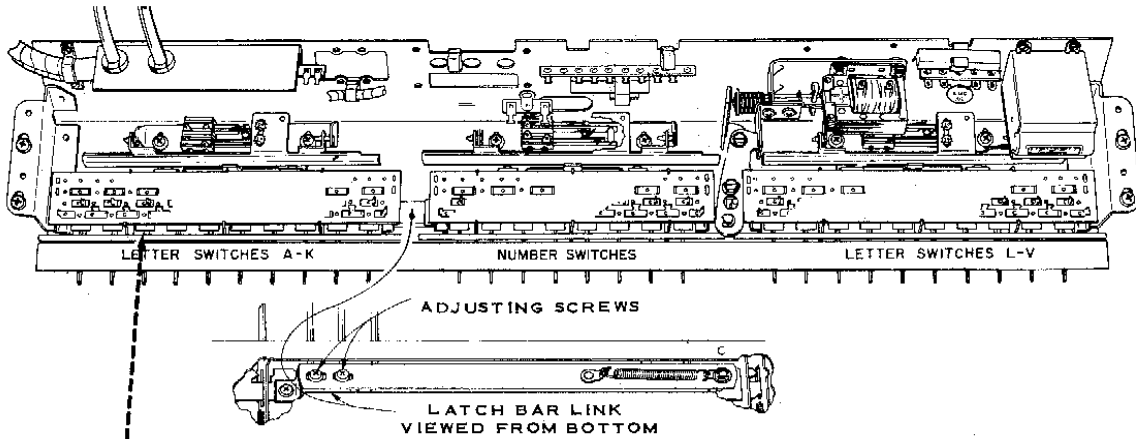

*NOTE: Before making this adjustment, Adjustment No. 1 must be correct, the latch bar solenoid must be in the energized position, all linkage and bars must be free to move without binding and there should be a gap between the release lever and the end of the latch bar solenoid plunger rod.*

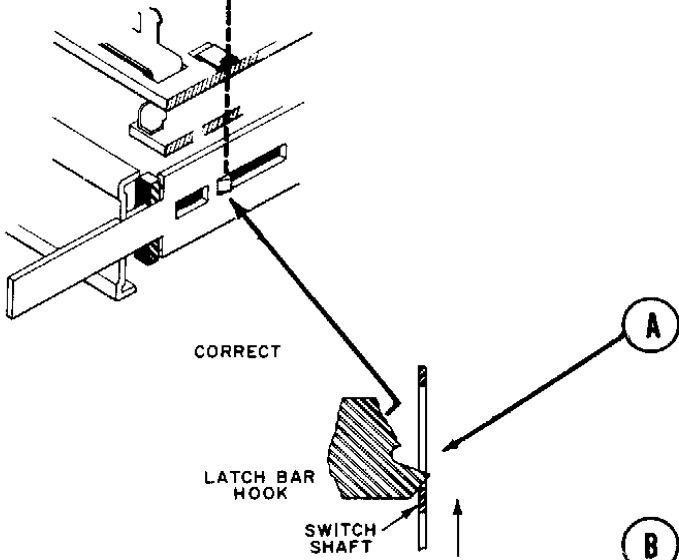

**A** Loosen the screw in the latch bar link between the A-K and the L-V letter switches and position the A-K switch latch bar so the tips of the latch bar locks extend  $1/64$  inch through the openings in the selector switch shafts.

**B** Securely tighten the adjusting screw.

**C** Check this adjustment by pressing a lettered switch in the A to K group and one in the L to V group while manually holding the latch bar solenoid in the energized position, then slowly release the solenoid. Both lettered switches should release at the same time. If the A-K latch bar is too far to the left, the switch in the A-K group will release first; if the A-K latch bar is too far to the right, the switch in the L-V group will release first.

# TORMAT ELECTRICAL SELECTOR, Type TES163

## ADJUSTMENT NO. 3 - NUMBER SWITCH

This adjustment positions the latch bar in the NUMBER selector switch so that when credits are established, the numbered selector switches will latch in the pressed-in position but permit change of selection by operating another numbered switch.

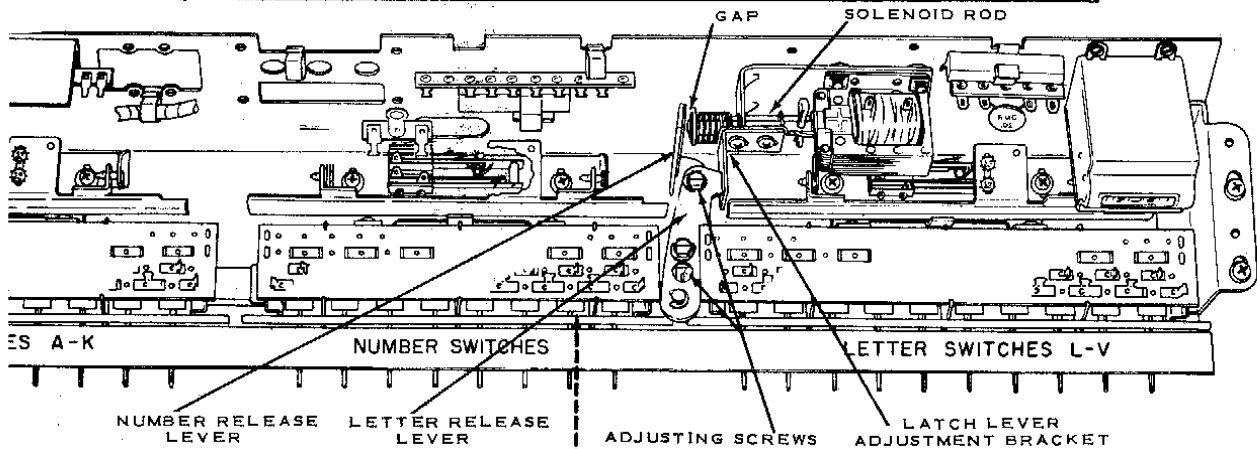

*NOTE: When making this adjustment the latch bar solenoid must be in the energized position, all linkage and bars must be free to move without binding and Adjustments No. 1 and No. 2 must be correct.*

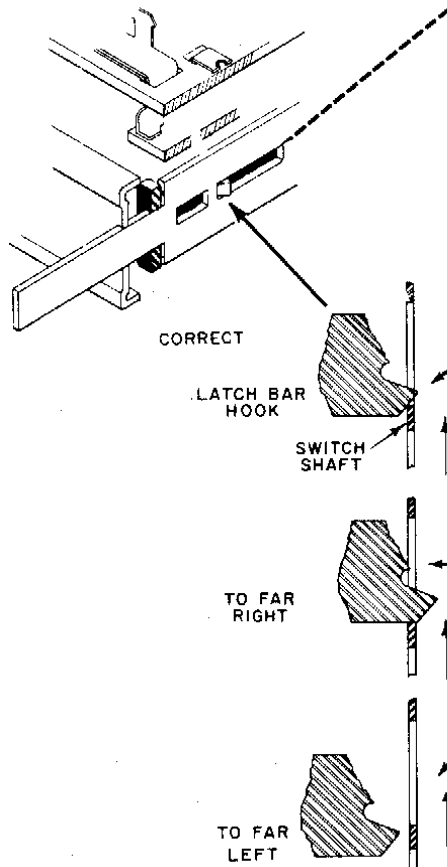

**A** The two screws that hold the number latch lever to the letter latch lever should be loosened just enough to permit the levers to be shifted.

**B** Insert and hold in place a shim 1/64 inch to 1/16 inch thick (a single thickness of match book cover) between the letter latch lever and the tip of the latch bar solenoid rod.

**C** While holding the letter latch lever against the latch lever adjustment bracket and the number latch lever against the shim and the solenoid rod, position the number latch lever so the tips of the latch bar hooks of the NUMBER selector switches extend 1/64 inch through the openings in the selector switch shafts.

**D** If the forward end of the number latch lever is too far to the right, the selector keys will be locked out. If the lever is too far to the left, the selector keys will not latch or the latching will be erratic.

**E** When the correct position for the latch lever has been established, the two screws that hold the letter and number levers together should be securely tightened and the shim removed.

TORMAT ELECTRICAL SELECTOR, Type TES163

TREADLE BAR AND SWITCH ADJUSTMENTS

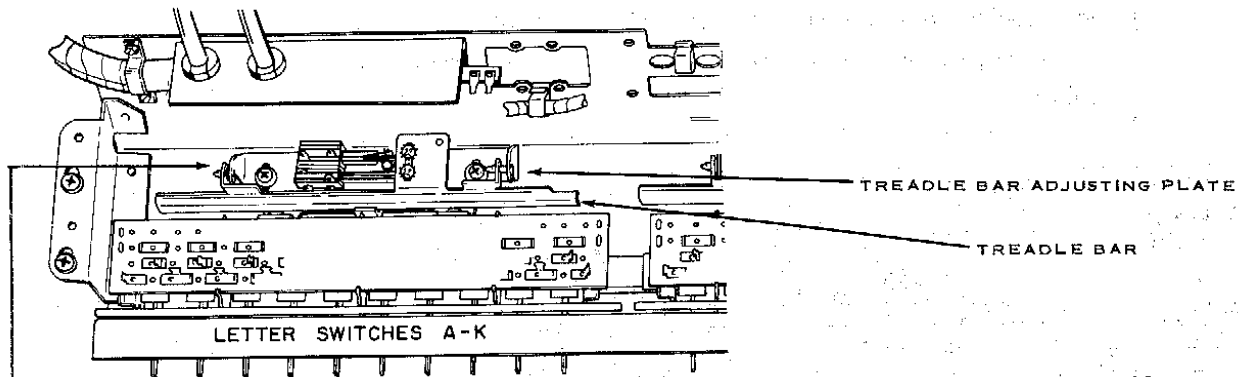

*NOTE: All treadle bars should move freely on their pivots to rest against the rubber bumpers and should have a small amount of end play.*

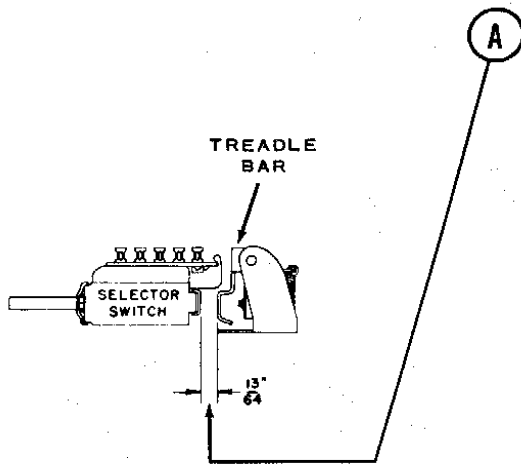

With the treadle bar against the rubber bumper in the treadle bar adjusting plate, position the plate (Screws A) so there is  $\frac{13}{64}$  inch (.203 inch) separation between the treadle bar and the frame of the selector switch. Use the shank of a No. 6 (.204 inch) or No. 7 (.201 inch) or a  $\frac{13}{64}$  inch twist drill for a spacing gage.

The timing of operation of the snap action Start Switches is adjusted by positioning the brackets for the entire switch assembly. **DO NOT ADJUST BY BENDING THE SNAP ACTION SWITCH BLADES.**

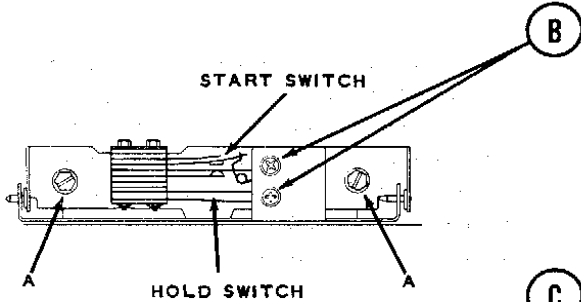

Loosen the bracket holding screws B, and position the switches so the Start Switch contacts close when the selector switches have approximately  $\frac{1}{32}$  inch more travel before latching by latch bars.

With all selector switches released:

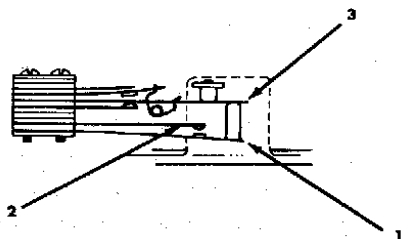

Adjust Blade No. 1 so its fibre lift bears against Blade No. 3 approximately 2 oz. (50 grams).

Adjust Blade No. 2 for  $\frac{1}{64}$  inch to  $\frac{1}{32}$  inch contact gap.

Readjust force of Blade No. 1 against Blade No. 3 so Blade No. 2 moves approximately blade thickness ( $\frac{1}{64}$  inch) when contacts close.

Check operation: Hold Switch must close before Start Switch closes and open after Start Switch opens.

# TORMAT ELECTRICAL SELECTOR, Type TES163

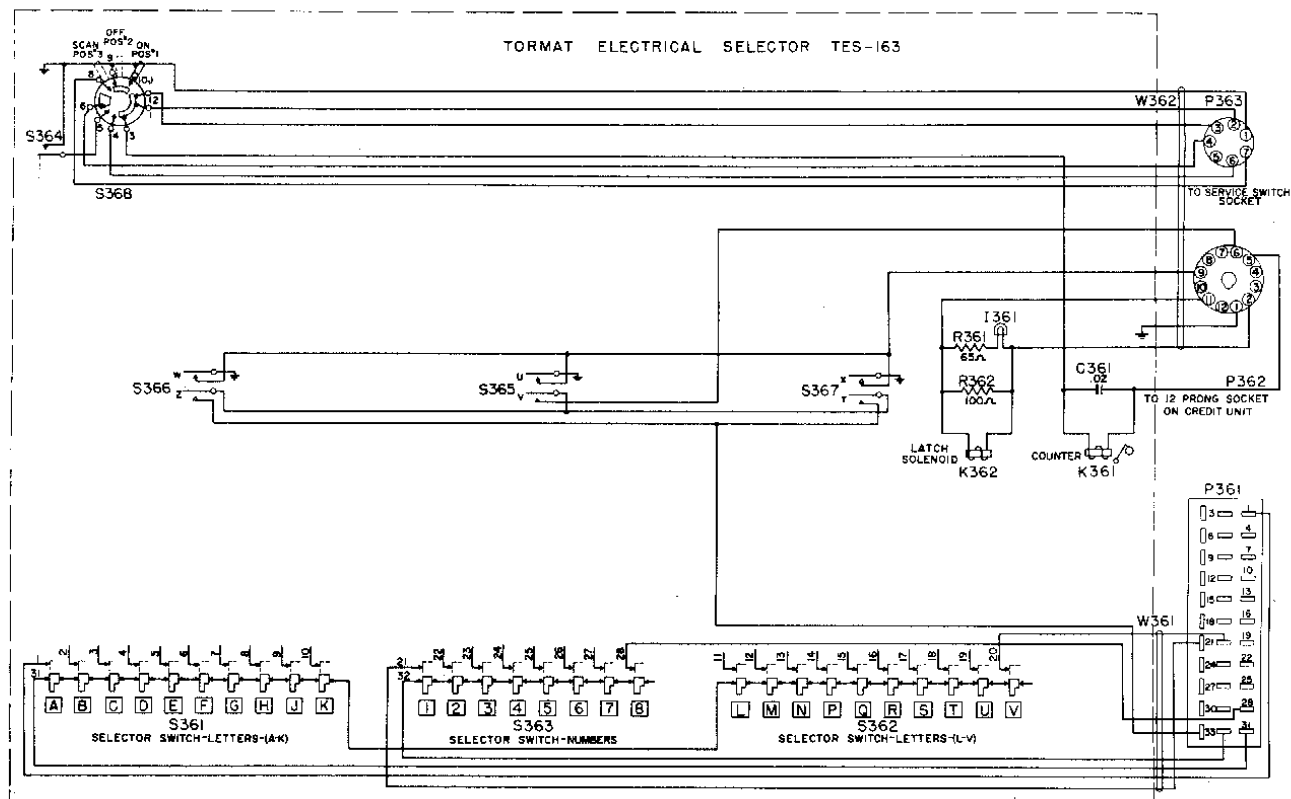

## PARTS LIST

Item	Part No.	Description
C361	86259	.02 Ceramic Condenser
I361	410823	Credit Lamp Socket Assy.
	505173	Panel Lamp No. 55
K361	411082	Counter Assembly
K362	410726	Latch Solenoid
P361	410573	Socket Assembly
P362	410708	Plug, 12 Prong
P363	408258	Plug, 7 Prong
R361	81178	Resistor 65 OHM 10 W.
R362	81183	Resistor 100 OHM 10 W.
S361	411066	Selector Switch (A-K)
S362	411067	Selector Switch (L-V)
S363	411257	Selector Switch (Number)
S364	410488	Credit Switch
S365	411073	Snap Switch
S366	411073	Snap Switch
S367	411073	Snap Switch
S368	411136	Service Switch
W361	411259	Matrix Cable
W362	411261	Control Cable