

SEEBURG

33-1/3 TRANSISTORIZED AUTO SPEED UNIT

Type

33-1/3 TASU1

SEEBURG

33-1/3 TRANSISTORIZED AUTO-SPEED UNIT, Type 33-1/3 TASU1

The 33-1/3 Transistorized Auto-Speed Unit Type 33-1/3 TASU1 supplies 44-cycle AC power to the motor of the Select-O-Matic phonograph mechanism when 33-1/3 RPM records are played. It is fully transistorized with power generated by a power converter that is controlled through circuits associated with the phonograph.

In addition to the power converter and its regulated power supply, the Unit includes a Power Relay, controls for power output and frequency and a trip circuit if the 44-cycle power supply should fail.

The power converter uses two transistors, Q754 and Q755, which are driven alternately into saturation. This results in a square wave voltage output at the secondary of the output transformer. When voltage is first applied to this circuit, one transistor or the other will begin to conduct. This initial current flow will induce voltage in the transformer winding which is connected to the base so that the conducting transistor will drive itself into saturation. At the same time an induced voltage is applied to the base of the other transistor holding it cut off. When the first transistor reaches saturation, the magnetic field in the primary of the output transformer will collapse. This collapsing field will induce voltage in the feedback winding of opposite polarity so the transistor that was conducting will be driven into cut-off and the transistor that was cut off will be biased in a forward direction, allowing it to conduct. The operation is recurrent at a 44.5 cycle rate. This frequency is determined by the negative voltage supplied to the converter from the power supply regulator, by the primary inductance of the output transformer and by the induced base voltage and the forward base bias on Q754 and Q755. This forward bias is adjusted with the speed control, R757. The frequency will also be affected by transistor gain and the capacitance of C754. The condenser, C754, determines to some extent the frequency of operation but its principal function is to reduce transient voltage peaks in the transformer primary. Without this condenser the switching transients would have amplitude in excess of the collector rating of the converter transistors. The 5K resistor across the secondary of the output transformer insures loading when the phonograph motor is operating on 60-cycle power.

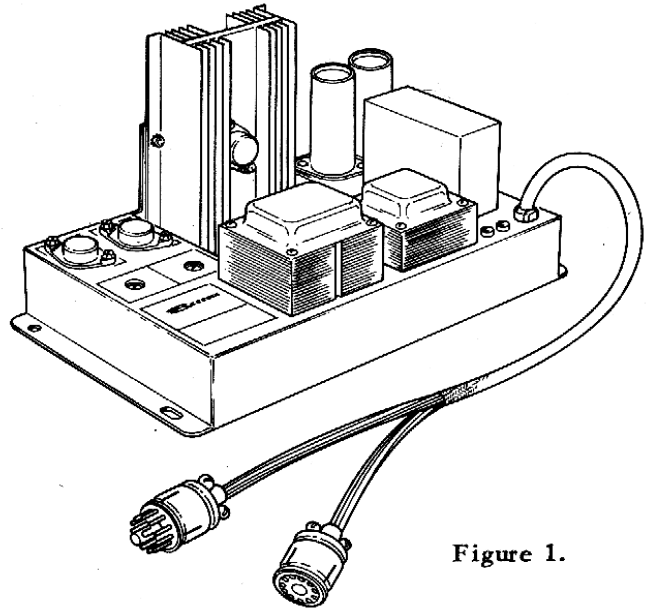

Figure 1.

Power for the converter is supplied from the transformer, T751, and is rectified by the silicon diodes, CR751 and CR752. The rectifier output is filtered by C751 with peak current limited by R751. At normal loading and line voltage the DC output is approximately 40 volts negative to ground at the collector of Q751.

The power supply regulator is of the series type in which the DC load current is through the collector-emitter circuit of Q751 and is controlled by the forward base bias of that transistor. The regulator, in addition to Q751, includes the zener diode, CR753, transistors Q752 and Q753, resistor R752 and the voltage divider R753, R754, and R755. R754 is the DRIVE control and is adjusted to obtain the desired DC voltage from the regulator.

A potential of approximately 15 volts is developed across the zener diode by current flow through the circuit which includes the diode, the collector-emitter circuit of Q753 and the 1.1K resistor, R752. This voltage remains constant for any current value within the design limits of the regulator and provides a reference voltage for comparison with the regulator output voltage. The comparison is made with the voltage at the arm of the drive control potentiometer, R754. Any variation in the regulator output voltage will change the base bias of transistor Q753 causing its collector current to change. This, in turn, will vary the voltage drop across R752 and, consequently, the bias on the base of Q752. The

33-1/3 TRANSISTORIZED AUTO - SPEED UNIT, Type TASU1

bias change on the base of Q752 affects a corresponding change of bias on the base of the series transistor, Q751, which then increases or decreases its collector-to-emitter current to compensate for the change of the regulator output voltage.

The regulator operation is as follows if it is assumed that its output voltage has decreased due to an increase in load current. The voltage at the arm of the drive control will decrease, causing a decrease in the base-to-emitter voltage of Q753. This will cause a decrease in the collector-to-emitter current through Q753 and result in less voltage drop across R752. As the drop across R752 decreases, the base voltage of Q752 becomes more negative (referred to ground and Q752 emitter). This causes a decrease of the collector-to-emitter resistance of Q752 and the voltage at its emitter and at the base of Q751 becomes more negative (referred to ground and Q751 emitter). This voltage increase at the base of Q751 is an increase in its forward bias so its collector-to-emitter resistance decreases resulting in lowered voltage drop between collector and emitter causing the regulator output voltage to increase to compensate for the initial reduction.

The output voltage recovery discussed in the above paragraph occurs so rapidly that a DC meter connected to the regulator output would not indicate a change for any load variation from no-load to the load of a stalled mechanism motor. Also, the output voltage will remain constant at the value to which it is adjusted over AC line inputs of from 90 to 130 volts.

The condenser, C753, improves the operation of the regulator in this application and reduces the work done by the comparator transistor, Q753, so it has lower power dissipation.

The regulator transistor, Q752, and the zener diode, CR753, are mounted in clips. These clips are heat sinks, the function of which is to conduct heat from the transistor and diode. The Unit should not be operated unless the parts are fully inserted in the clips.

The converter transistors, Q754 and Q755, use the Unit chassis for heat dissipation and must be held firmly to it with the mounting

screws. The cases of these transistors are insulated from the chassis with mica washers. If one of the transistors is removed or changed, a new mica washer should be used and the washer should be coated with a liberal amount of silicone grease on both sides. Excess grease should be wiped off after the transistor is securely fastened in place. The regulator series transistor, Q751, is mounted on a black, vertical-ribbed heat sink. A silicone grease coated washer must also be used under the transistor for electrical insulation which does not retard heat-conduction. The air space between the fins of this sink must not be blocked.

The SPEED control, R757, adjusts the converter output frequency by varying the forward base bias on Q754 and Q755. However, the frequency is also affected by the regulated DC voltage to the converter. This latter is determined by the adjustment of the DRIVE control, R754. In the application of the TASU1, the desired frequency for turntable speed of 33-1/3 RPM is approximately 44.5 cycles and is determined by using a strobe disc on the turntable.* The adjustment should be made as follows:

1. Operate the phonograph motor from the TASU1 for approximately three minutes.
2. Set the SPEED control for correct speed as indicated by the strobe disc.
3. If there is no position of the SPEED control that will give the correct motor speed, turn the DRIVE control 1/8-turn to the right to increase speed or to the left to decrease speed, whichever is needed, and repeat step No. 2.
4. Repeat steps No. 3 and 2 as required until correct motor speed is obtained.

Steps No. 4 and 3 will not be necessary unless the DRIVE control has been altered or unless a component part of the Auto-Speed Unit has been changed. Correct speed adjustments will result in regulated DC voltage to the converter (as read across C752) of from 20.5 to 26 and an output voltage as read at the test jacks adjacent to the controls of from 70 to 90 volts.

The output voltage and frequency remain relatively constant over a wide range of supply line voltage and load conditions because of the inherent stability achieved by regulating the AC power to the converter.

* 7" STROBE DISC, PART NO. 508487 FOR 60 CYCLE; PART NO. 508478 FOR 50 CYCLE.

33-1/3 TRANSISTORIZED AUTO - SPEED UNIT, Type TASU1

The Power Relay, K751, when energized transfers the phonograph motor connections from 60- to 44-cycle supply. It is controlled by a circuit that includes a single-pole, normally closed clamp arm switch that is actuated by the record clamp arm on the mechanism. The size of the record spindle hole determines how far the clamp arm moves and whether or not the switch is actuated.

The 33-1/3 RPM record has a 5/16 inch spindle hole. It centers on the turntable with a 5/16 inch clamp arm centering pin and is held against the turntable by the face of the concentric 1-1/2 inch, 45 RPM centering "pin". When a 45 RPM record, with its 1-1/2 inch spindle hole, is played, the 1-1/2 inch diameter pin passes through it and the record is held against the turntable by the flat surface of the clamp disc. When a 45 RPM record is clamped, the clamp arm moves inward far enough to open the clamp arm switch. There is less arm movement when a 33-1/3 RPM record is clamped and the switch remains closed.

The clamp arm switch, as shown in Figure 2, is in series with a contact on the cam switch and the IC contact on the reset lever switch. It provides a 25 volt circuit for the Power Relay. The IC contact is closed when a record is tripped from play. The cam switch contact is closed only in the playing position. The clamp arm switch is closed only when a 33-1/3 RPM record is clamped. The only time the relay is energized, then, is when the mechanism is playing a 33-1/3 RPM record. At all other times - during transfer, scan and while playing a 45 RPM

record, the relay is not energized and the motor is operating at 60 cycles.

Contact E on the Power Relay closes when the relay is energized and applies 30 to 35 volts to the diode CR755 which, in turn, is connected to the grid of the trip 2050 in the phonograph. The circuit is shown in Figure 3. This negative voltage is in the reverse direction for the diode and is greater (more negative) than the 2050 bias supply so the normal bias voltage does not change. The 30 to 35 volts is derived from the 44 cycle supply through the diode (rectifier) CR754 and the voltage divider R760 and R761. When a 33-1/3 RPM record is not on the turntable, contact E will be open and the circuit from the 2050 bias supply through CR755 will be open.

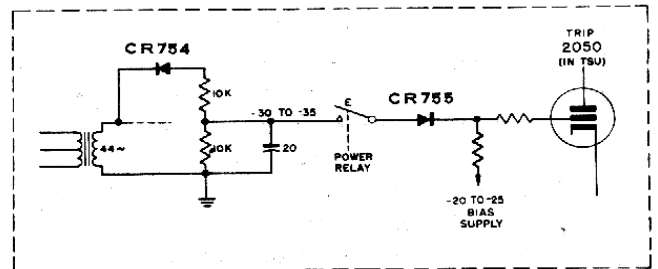
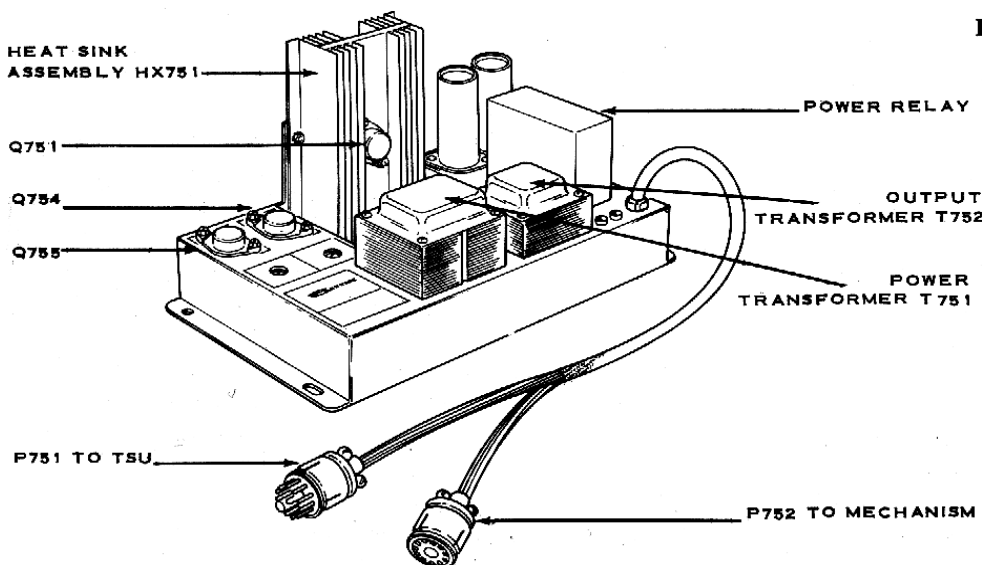
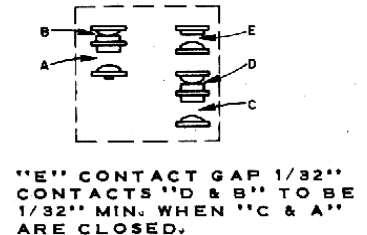
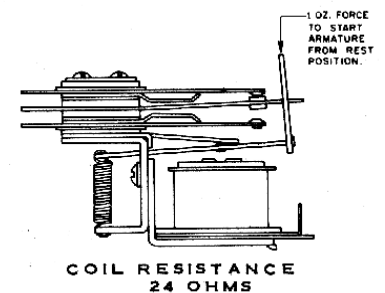

Figure 3. Trip Control Circuit

If the 44-cycle supply should fail while a 33-1/3 RPM record is playing or if there should be no 44-cycle power available at the time the relay is energized, the bias for the 2050 will be grounded through CR755 and R760. The 2050 will then fire and the mechanism will trip from the play position. When the trip occurs, the IC contact of the reset lever switch will open, permitting the power relay to drop out so the motor is connected to the 60 cycle supply for continued operation.



POWER RELAY ADJUSTMENTS



33-1/3 TRANSISTORIZED AUTO - SPEED UNIT, Type TASU1

The chart lists the values of Voltage and Resistance at various Test Points in the TASU1. These represent values on a normal unit. Defects in an abnormal unit can be isolated by comparing the readings of the abnormal unit with the values on this chart.

Voltage and resistance measurements indicated will differ from unit to unit and should be used as a comparative reference. It should be recognized that meter tolerances vary but are usually 3% to 5% of Full Scale.

Check resistance measurements before applying power to unit. Use an ohmmeter on only those test points that have resistance measurements indicated on the chart below. Use of an ohmmeter on the other points has no significance and may damage the transistors in the circuit.

Before checking voltages, adjust Drive Control (R754) so Test Point 'L' is -24VDC with no load. A normal load for the Auto-Speed Unit would be either a Select-O-Matic mechanism motor or a 500 ohm, 50 watt resistor across the output of the Auto-Speed Unit.

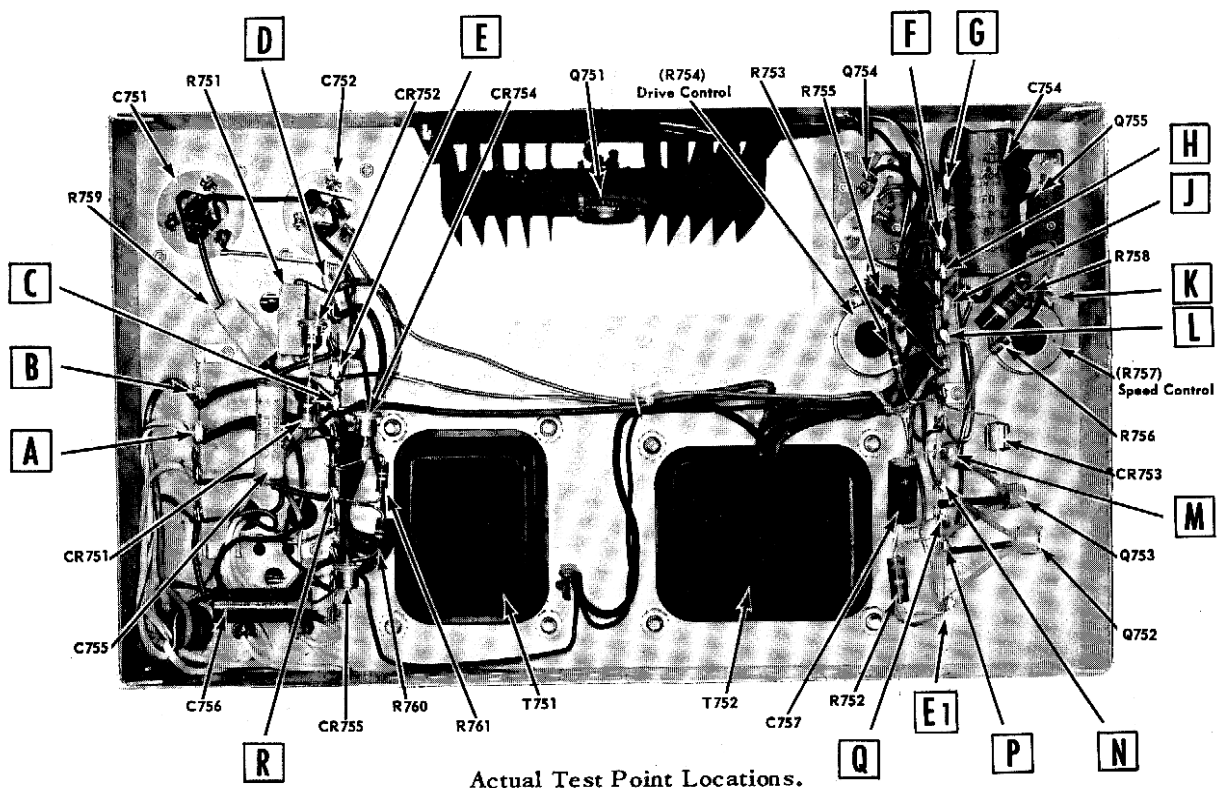

Actual Test Point Locations.

TEST POINTS	REVERSE RESISTANCE	FORWARD RESISTANCE	VOLTAGE (No Load)	VOLTAGE (Load)
A to B	13 ohms		117VAC	
C to ground	4.6 ohms		89VAC	84VAC
D to ground	1.5 ohms		.75VAC	1.6VAC
E to ground	More than 20K (Note 1)	Less than 1K (Note 1)	-42VDC	-35.5VDC
F to ground	—	—	2VAC	1.45VAC
G to J	1.4 ohms		48VAC	45VAC
G to ground	—	—	-23.5VDC	-23VDC
H to ground	—	—	2VAC	1.45VAC

TEST POINTS	REVERSE RESISTANCE	FORWARD RESISTANCE	VOLTAGE (No Load)	VOLTAGE (Load)
J to ground	—	—	-23.5VDC	-23VDC
K to ground	—	—	1.65VAC (Note 2)	1VAC (Note 2)
L to ground	160 to 320 ohms (Note 2)	8 ohms	-24VDC (Note 3)	-23.6VDC (Note 3)
M to ground	—	—	-15.5VDC	-15.5VDC
N to ground	—	—	-22VDC	-21.8VDC
P to ground	—	—	-18.5VDC	-22VDC
Q to ground	—	—	-15.9VDC	-15.9VDC
R to ground	10,000 ohms	6,000 ohms	-25.5VDC	-24VDC

NOTES: (1) With input to Regulator disconnected at E1; (2) Dependent on Speed Control (R757) setting; (3) Dependent on Drive Control (R754) setting.

SEEBURG

33-1/3 TRANSISTORIZED AUTO-SPEED KIT, Type 33-1/3 TASU1 WITH THE SELECT-O-MATIC Q100 & Q160, Y100 & Y160 MODELS

The 33-1/3 Transistorized Auto-Speed Kit, Part No. 508946, is for use with the Select-O-Matic Q100 and Q160, Y100 and Y160 Models for playing intermixed 45 rpm. and 33-1/3 rpm., 7-inch records.

INSTALLATION

1. Position the Auto-Speed Unit on the floor of the phonograph (Figure 1) and secure in position using four 10-32 x 3/4 inch Sems screws provided.
2. Unplug Mechanism Cable from socket J502 of Tormat Selector Unit and plug it into 11-prong socket, P752, of Auto-Speed Unit Cable.
3. Insert 11-prong plug, P751, of Auto-Speed Unit Cable into the Tormat Selector Unit socket, J502, vacated in step 2.

ADJUSTMENT:

1. Replace a record with the Seeburg 33-1/3 Auto-Speed Disc, Part No. 508487. This disc is to be used only with a 60 cps light source.

2. Select Strobe Disc on to the mechanism turntable and carefully prop pickup arm out of the way.
3. Allow unit to run approximately 3 minutes.
4. Set the motor speed to 33-1/3 RPM by adjusting the Motor Speed Control so that the outer and inner bands on the Strobe Disc move in opposite directions.
5. If this adjustment does not bring the motor to the proper speed, turn the Motor Drive Control clockwise or counter clockwise, whatever is needed, by 1/8 turn and repeat step 4.
6. Repeat Steps 5 and 4 as many times as necessary.
7. *Note:* Usually Steps 5 and 6 will not be necessary.
8. Remove the Strobe Disc.
9. Load 33-1/3 RPM. Records and insert associated Programming Strips.
10. Install Decal, Part No. 484284.

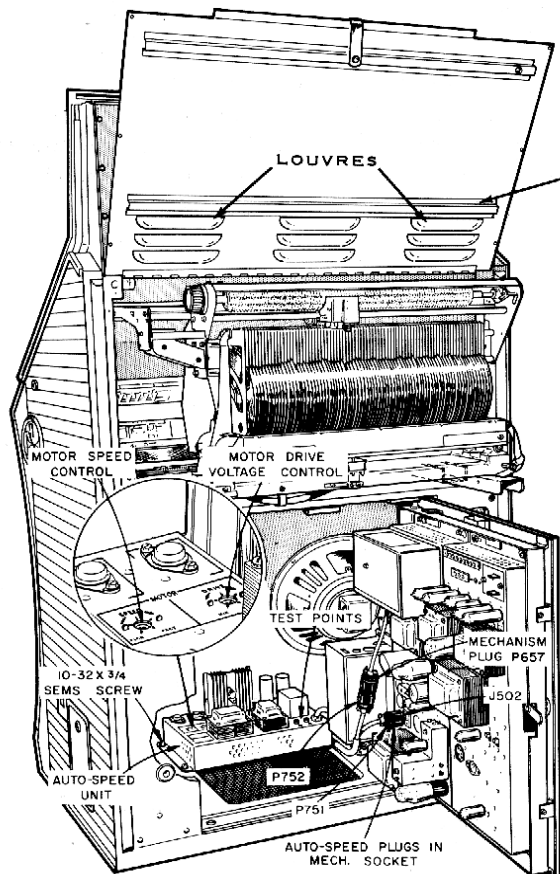

Figure 1. Auto-Speed Unit Installed

IMPORTANT VENTILATION NOTES

1. On some "Q" models in which the access panel has no louvres, replace with Part No. 483143.
2. On some "Q" models in which no opening has been provided under the Auto-Speed Unit, cut as shown in Figure 2.
3. One inch minimum clearance between bottom of phonograph cabinet and floor or carpet; use caster supports if required.
4. Two inch minimum clearance from back of phonograph to wall, use spacers if required.
5. All ventilation holes must be free of paper, labels and other obstructions.

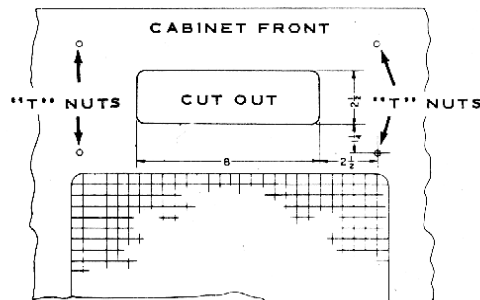

Figure 2. Cabinet Opening

MODIFICATION OF SELECT-O-MATIC MECHANISM, Type 145ST5 & 160ST4

(Used on Q100 & Q160 Models) FROM CODE A TO CODE B

Clamp Arm Switches wired as in Code A Mechanisms (long contact to ground) cause the mechanism motor to stop completely in the event of Auto-Speed Unit failure. Code B mechanisms will trip and move to another record. Code B mechanisms can be identified by a rubber bumper on the end of the clamp arm adjusting screw or an insulator on the switch blade.

The Clamp Arm Switch wiring revisions associated with the Code B mechanisms are such as to cause the mechanism to trip from play position in case of Auto-Speed Unit failure while a 33-1/3 RPM record is playing and permits the motor to continue operation at 60 cycles.

The following procedure details Code A to Code B modification requirements:

1. Remove the wire connecting the Clamp Arm Switch to a ground lug.
2. Remove the Pickup Arm Assembly from the mechanism.
3. Add a wire from the switch terminal vacated in step 1 to the lower (No. 2) IC contact of the Reset Lever Switch and route as shown in *Figure 3*.
4. Replace the Pickup Arm Assembly.

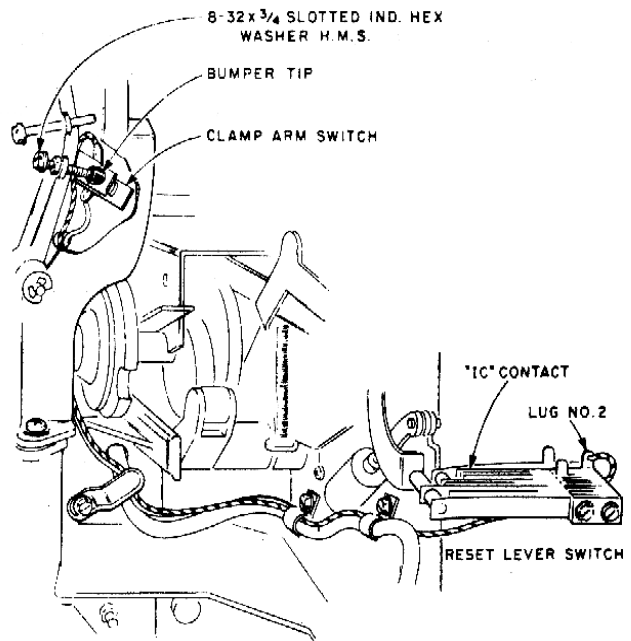

Figure 3. Clamp Arm Switch Rewiring

5. Replace the existing Clamp Arm Switch adjusting screw with shorter screw, Part No. 914725, and Rubber Bumper, Part No. 245983.
6. Adjust the Clamp Arm Switch so that with mechanism in Scan position, the switch is closed; and in Play position with a standard 45 RPM (1.5 inch hole record) clamped between the turntable and clamp Arm Disc, the Clamp Arm Switch gap is 1/32 inch.

33-1/3 TRANSISTORIZED AUTO - SPEED UNIT, Type TASU1

NOTES:
 1. ALL RECEPTACLES ARE AS VIEWED FROM THE CABLE END.
 2. ALL POT DIRECTIONS ARE AS VIEWED FROM TOP OF CHASSIS.

PART NO. 307500

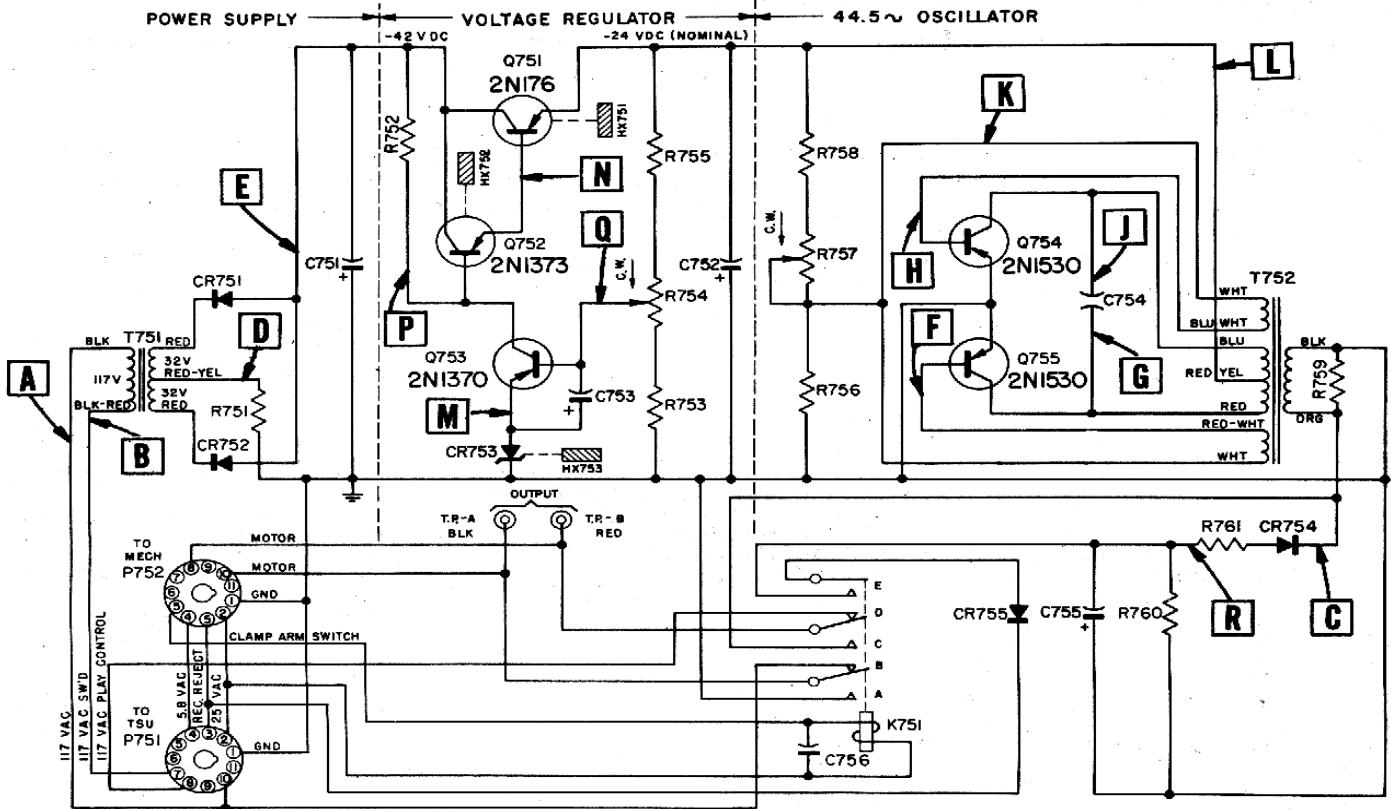

Schematic Diagram - 33-1/3 Transistorized Auto-Speed Unit, showing Test Points.

PARTS LIST

Item	Part No.	Description	Item	Part No.	Description
—	307470	33-1/3 Transistorized Auto-Speed Unit	Q751 *	309406	2N176 Transistor
C751	87704	500 Mfd 50 V. Lytic	Q752	309409	2N1373 Transistor
C752	87705	800 Mfd 30 V. Lytic	Q753	309408	2N1370 Transistor
C753	87697	9 Mfd 6 V. Lytic	Q754 *	309407	2N1530 Transistor
C754	87708	10 Mfd 100 V. Non-Polarized Lytic	Q755 *	309407	2N1530 Transistor
C755	87690	20 Mfd 75 V. Lytic		* 84312	Power Transistor Socket
C756	86235	0.05 Mfd 200 V. Paper		* 375074	Mica Insulator
CR751	309387	Silicon Rectifier		* 53015	Silicone Grease (2 oz. tube)
CR752	309387	Silicon Rectifier	R751	81218	1.5 Ohm 5 W. 10%
CR753	309395	IN3024A Silicon Zener Diode	R752	82865	1,100 Ohm 1 W. 5%
CR754	309396	Silicon Rectifier	R753	82613	2,400 Ohm ½ W. 5%
CR755	309396	Silicon Rectifier	R754	307486	1,500 Ohm Potentiometer
HX751	307489	Heat Sink Assembly	R755	82867	360 Ohm 1 W. 5%
HX752	307505	Heat Sink Clamp	R756	82404	22 Ohm ½ W. 10%
HX753	307504	Heat Sink Clamp	R757	307486	1,500 Ohm Potentiometer
K751	307422	Power Relay	R758	82858	680 Ohm 2 W. 10%
	307442	Coil & Frame	R759	81219	5,000 Ohm 5 W. 10%
	307441	Switch Stack (E,D,C)	R760	82436	10,000 Ohm ½ W. 10%
	307440	Switch Stack (B,A)	R761	82436	10,000 Ohm ½ W. 10%
P751	249936	11 Prong Plug	T751	307483	Power Transformer
P752	307457	8 Contact Socket	T752	307484	Output Transformer

* USE MICA INSULATOR COATED WITH LIBERAL AMOUNT OF SILICONE GREASE ON BOTH SIDES WHEN MOUNTING POWER TRANSISTORS INDICATED WITH (*).

33-1/3 TRANSISTORIZED AUTO - SPEED UNIT, Type TASU1

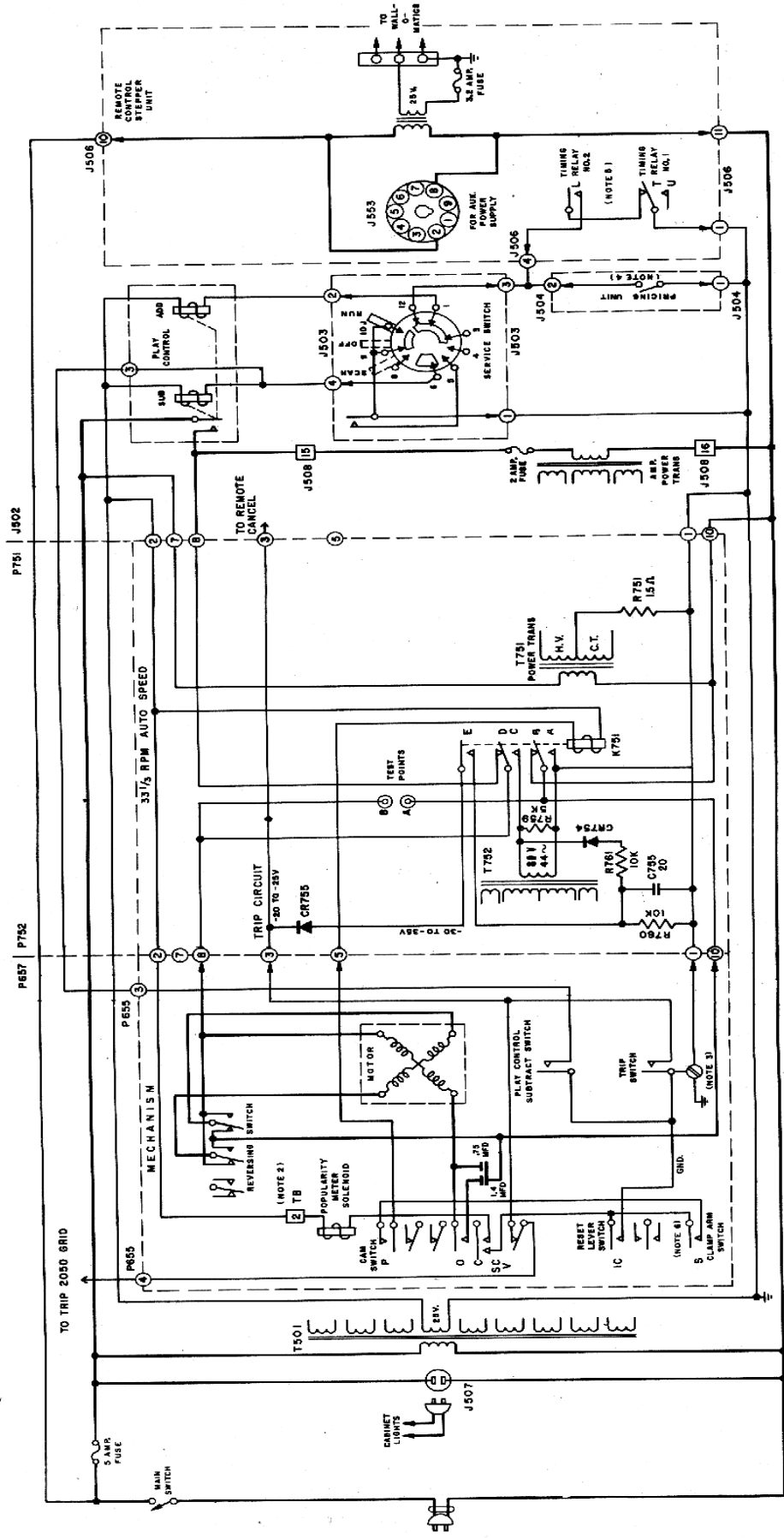

- 1. THIS SYMBOL INDICATES A SOCKET IN THE FORMAT SELECTOR UNIT. NUMERAL IN CIRCLE IS CONTACT OR TERMINAL NUMBER. ARROW INDICATES MATING PLUG TERMINAL.
- 2. THIS SYMBOL INDICATES A TERMINAL OF THE TERMINAL STRIP ON MECHANISM CARRIAGE. NUMERAL IN BOX IS TERMINAL NUMBER. BEGINS WITH 1 AT BOTTOM OF STRIP.
- 3. CARRIAGE GROUND. CONNECTION BELOW TERMINAL STRIP.
- 4. CIRCUIT MOMENTARILY CLOSED WHEN ELECTRICAL SELECTOR.
- 5. CIRCUIT MOMENTARILY CLOSED THROUGH L AND T WHEN SELECTION IS MADE BY REMOTE OPERATION.
- 6. OPENS WHEN 45 RPM RECORD IS CLAMPED.

Figure 2. Power and Control Wiring with 33-1/3 TASU1